

***DIN 69880***

***HAAS BMT 65***

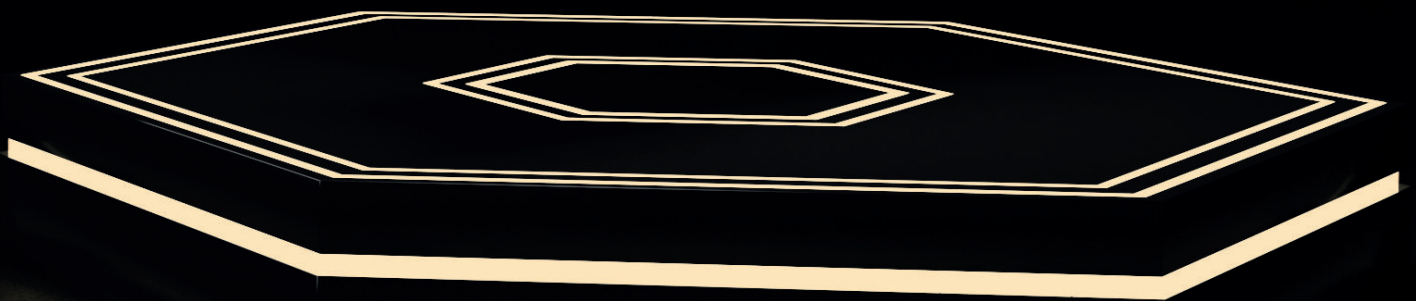
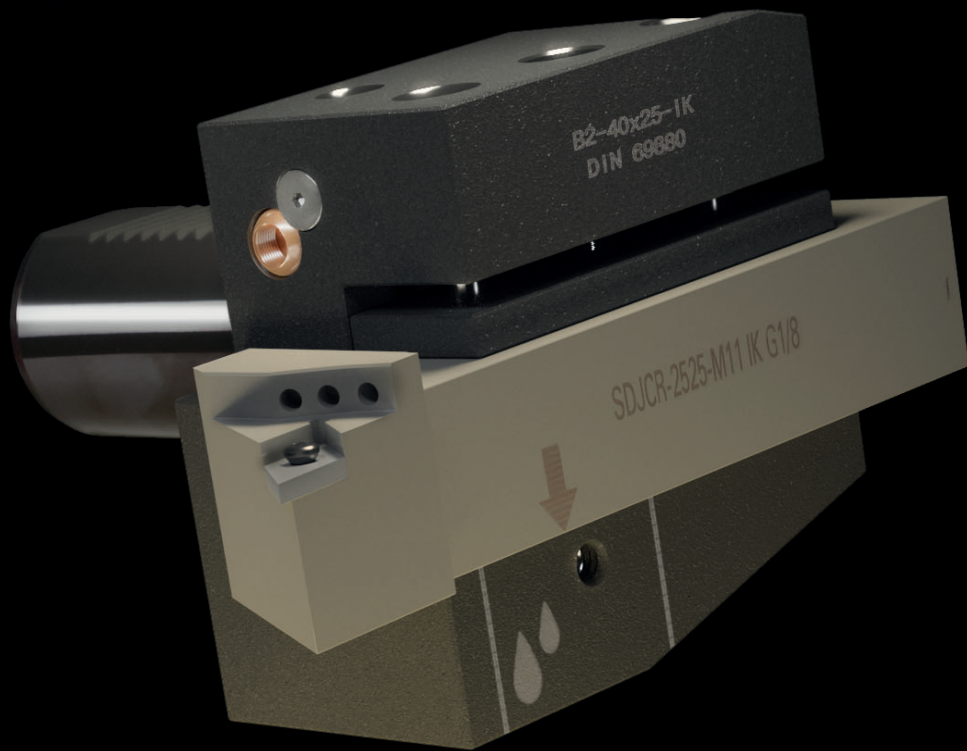

**WERKZEUGAUFNAHMEN**  
**DIN 69880 (VDI 3425)**  
**DIN ISO 10889**

**TOOLHOLDERS**  
**DIN 69880 (VDI 3425)**  
**DIN ISO 10889**

**PORTE-OUTILS**  
**DIN 69880 (VDI 3425)**  
**DIN ISO 10889**

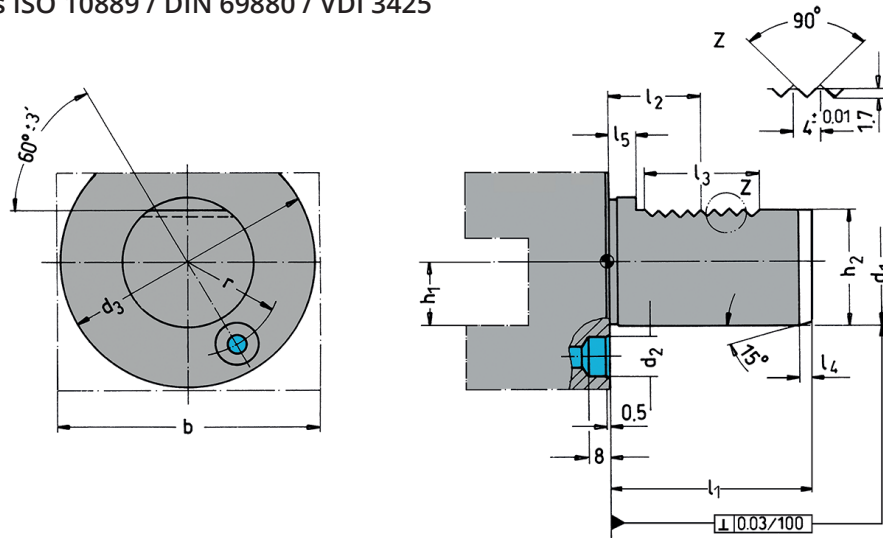

d <sub>1</sub> h <sub>6</sub>	b	h <sub>1</sub> max.	d <sub>2</sub>	d <sub>3</sub>	h <sub>2</sub> ± 0,1	r ± 0,02	l <sub>1</sub> max.	l <sub>2</sub> ± 0,05	l <sub>3</sub> max.	l <sub>4</sub> max.	l <sub>5</sub>
16	42	12	8	40	15,0	14,5	32	12,7	16	2	3,5
20	52	16	10	50	18,0	18,0	40	21,7	24	2	7,0
25	60	16	10	58	23,5	21,0	48	21,7	24	2	7,0
30	70	20	14	68	27,0	25,0	55	29,7	40	2	7,0
40	85	25	14	83	36,0	32,0	63	29,7	40	3	7,0
50	100	32	16	98	45,0	37,0	78	35,7	48	3	8,0

7

**Werkstoff:** Legierter Einsatzstahl mit einer Zugfestigkeit im Kern von min. 800 N / mm<sup>2</sup>. Einsatzgehärtet HRC 60 ± 2 (HV 700 ± 50), Härtetiefe 0,8 mm ± 0,2 mm, brüniert und präzisionsgeschliffen.

**Ausführung:** Mit innerer Kühlmittelzufuhr bzw. mit Gewindeanschluss für externe Kühlmittelzufuhr.

**Material:** Alloyed case-hardened steel, tensile core strength of min. 800 N / mm<sup>2</sup>. Case hardened HRC 60 ± 2 (HV 700 ± 50), hardening depth 0.8 mm ± 0.2 mm, black-finished and precisely grinded.

**Version:** With internal coolant resp. with threaded connection for external coolant.

**Matière:** Acier de cémentation allié. Résistance à la traction dans le noyau de min 800 N / mm<sup>2</sup>. Cémentation à HRC 60 ± 2 (HV 700 ± 50), profondeur de cémentation 0,8 mm ± 0,2 mm, bruni et rectifié précisément.

**Version:** Avec arrosage interne respectivement avec raccord fileté pour arrosage externe.

### Werkzeugzuordnung für Scheibenrevolver

Tool assignment for disc turrets

Assignation des outils pour machines avec tourelle à disque

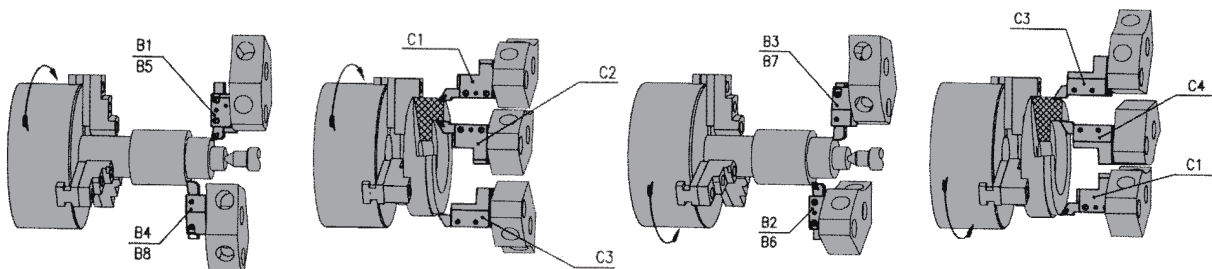

Einsatz von Werkzeughaltern bei linker Spindeldrehrichtung  
 Application of tool holders with anti-clockwise spindle rotation  
 Utilisation d'attachements avec la broche en sens anti-horaire

Einsatz von Werkzeughaltern bei rechter Spindeldrehrichtung  
 Application of tool holders with clockwise spindle rotation  
 Utilisation d'attachements avec la broche en sens horaire



Static and power-driven tools for CNC lathes and machining centers  
 Porte-outils statiques ou rotatifs pour tours CNC

7.05  B1	7.07  B2	7.09  B3	7.11  B4
7.13  B5	7.14  B6	7.15  B7	7.16  B8
7.17  C1	7.19  C2	7.21  C3	7.23  C4
7.25   7.26  D1 D2	7.27   7.28  AR AL	7.29  E3	7.30  E4
7.31  E1	7.32  E2	7.33  E2	7.35  E2
7.37  F1	7.38  Z2	7.39  Z2	7.41  Z2
7.42  A1 A2	7.43  A1 A2	7.45   7.46  A1 A2	7.47  A1 A2
7.48  HAAS BMT 65	7.52  HAAS BMT 65	7.54  HAAS BMT 65	7.56  HAAS BMT 65





**Verwendung:**  
Vorwiegend für Außenbearbeitung.  
Zum Plan Einstechen.

**Application:**  
Mainly for external machining.  
For face machining.

**Application:**  
Principalement pour usinage extérieur.  
Pour carottage.

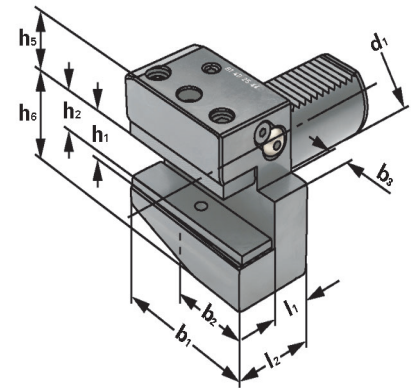

ISO 10889  
DIN 69880

B1

Bestell-Nr. Order no. Référence	Abmessung Size Dimension	d <sub>1</sub>	h <sub>1</sub>	h <sub>2</sub>	l <sub>2</sub>	l <sub>1</sub>	b <sub>1</sub>	b <sub>2</sub>	b <sub>3</sub>	h <sub>5</sub>	h <sub>6</sub>
169.31.12	B1 - 16 × 12 × 24	16	12	-	24	13	42	23	5	20	22
209.31.16	B1 - 20 × 16 × 30	20	16	12	30	16	55	30	7	25	30
259.31.16	B1 - 25 × 16 × 30	25	16	12	30	16	55	30	7	25	30
309.31.20	B1 - 30 × 20 × 40	30	20,5	16	40	22	70	35	10	28	38
409.31.25	B1 - 40 × 25 × 44	40	25	20	44	22	85	42,5	12,5	32,5	48
509.31.32	B1 - 50 × 32 × 55	50	33	26	55	30	100	50	16	35	60

7

**Ausführung:** Mit einstellbarer Kugelspritzdüse und Unterlegplatte  
**Version:** With adjustable spray nozzle and shim  
**Version:** Avec gicleur ajustable et semelle





Radial toolholders form B1 right, short - for tools with internal coolant  
 Porte-outils radials forme B1 droite, pour - outils avec arrosage interne



**Verwendung:**  
 Vorwiegend für Außenbearbeitung.  
 Zum Plan Einstechen.

**Application:**  
 Mainly for external machining.  
 For face machining.

**Application:**  
 Principalement pour usinage extérieur.  
 Pour carottage.

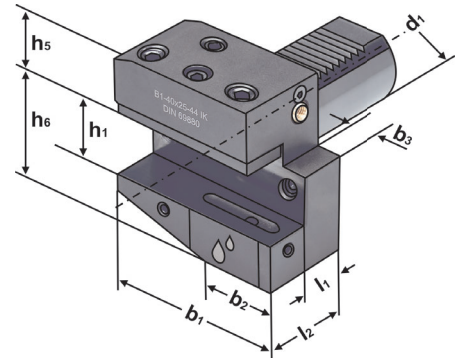

ISO 10889  
 DIN 69880

B1

IC

Bestell-Nr. Order no. Référence	Abmessung Size Dimension	d <sub>1</sub>	h <sub>1</sub>	l <sub>2</sub>	l <sub>1</sub>	b <sub>1</sub>	b <sub>2</sub>	b <sub>3</sub>	h <sub>5</sub>	h <sub>6</sub>
309.31.20.IK	B1 - 30 × 20 × 40	30	20	40	22	70	35	10	28	38
409.31.25.IK	B1 - 40 × 25 × 44	40	25	44	22	85	42,5	12,5	32,5	48
509.31.32.IK	B1 - 50 × 32 × 55	50	32	55	30	100	50	16	35	60

**Ausführung:** Mit einstellbarer Kugelspritzdüse  
**Version:** With adjustable spray nozzle  
**Version:** Avec gicleur ajustable

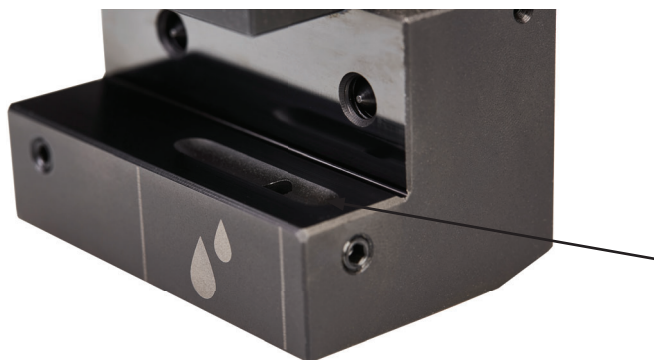

Übergabe für Kühlmittel  
 Coolant supply  
 Jonction d'arrosage

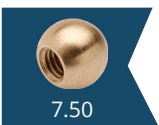



**Verwendung:**  
Vorwiegend für Außenbearbeitung.  
Zum Plan Einstechen.

**Application:**  
Mainly for external machining.  
For face machining.

**Application:**  
Principalement pour usinage extérieur.  
Pour carottage.

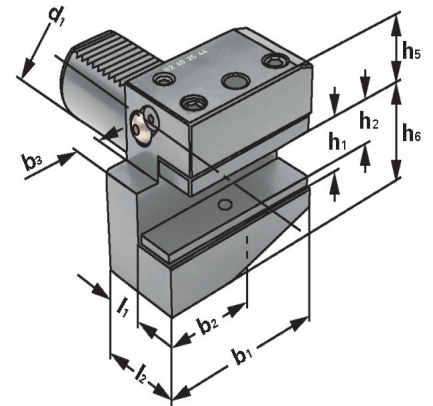

ISO 10889  
DIN 69880

B2

Bestell-Nr. Order no. Référence	Abmessung Size Dimension	d <sub>1</sub>	h <sub>1</sub>	h <sub>2</sub>	l <sub>2</sub>	l <sub>1</sub>	b <sub>1</sub>	b <sub>2</sub>	b <sub>3</sub>	h <sub>5</sub>	h <sub>6</sub>
169.32.12	B2 – 16 × 12 × 24	16	12	-	24	13	42	23	5	20	22
209.32.16	B2 – 20 × 16 × 30	20	16	12	30	16	55	30	7	25	30
259.32.16	B2 – 25 × 16 × 30	25	16	12	30	16	55	30	7	25	30
309.32.20	B2 – 30 × 20 × 40	30	24,5	20,5	40	22	70	35	10	23,5	42,5
409.32.25	B2 – 40 × 25 × 44	40	28	23	44	22	85	42,5	12,5	23,5	42,5
509.32.32	B2 – 50 × 32 × 55	50	33	26	55	30	100	50	16	35	60

**Ausführung:** Mit einstellbarer Kugelspritzdüse und Unterlegplatte  
**Version:** With adjustable spray nozzle and shim  
**Version:** Avec gicleur ajustable et semelle





Radial toolholders form B2 left, short - for tools with internal coolant  
 Porte-outils radials forme B2 gauche, court - pour outils avec arrosage interne



**Verwendung:**  
 Vorwiegend für Außenbearbeitung.  
 Zum Plan Einstechen.

**Application:**  
 Mainly for external machining.  
 For face machining.

**Application:**  
 Principalement pour usinage extérieur.  
 Pour carottage.

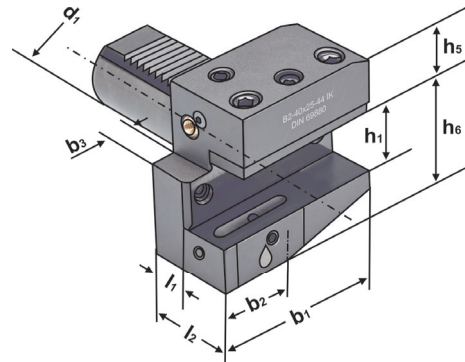

ISO 10889  
 DIN 69880

B2

IC

Bestell-Nr. Order no. Référence	Abmessung Size Dimension	d <sub>1</sub>	h <sub>1</sub>	l <sub>2</sub>	l <sub>1</sub>	b <sub>1</sub>	b <sub>2</sub>	b <sub>3</sub>	h <sub>5</sub>	h <sub>6</sub>
309.32.20.IK	B2 - 30 × 20 × 40	30	20	40	22	70	35	10	28	38
409.32.25.IK	B2 - 40 × 25 × 44	40	25	44	22	85	42,5	12,5	32,5	48
509.32.32.IK	B2 - 50 × 32 × 55	50	32	55	30	100	50	16	35	60

**Ausführung:** Mit einstellbarer Kugelspritzdüse  
**Version:** With adjustable spray nozzle  
**Version:** Avec gicleur ajustable

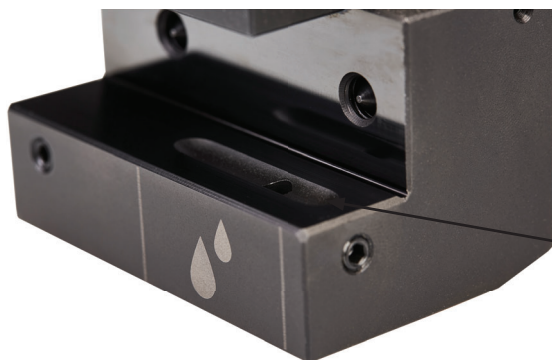

Übergabe für Kühlmittel  
 Coolant supply  
 Jonction d'arrosage

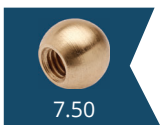





**Verwendung:**  
Vorwiegend für Außenbearbeitung.  
Zum Plan Einstechen.

**Application:**  
Mainly for external machining.  
For face machining.

**Application:**  
Principalement pour usinage extérieur.  
Pour carottage.

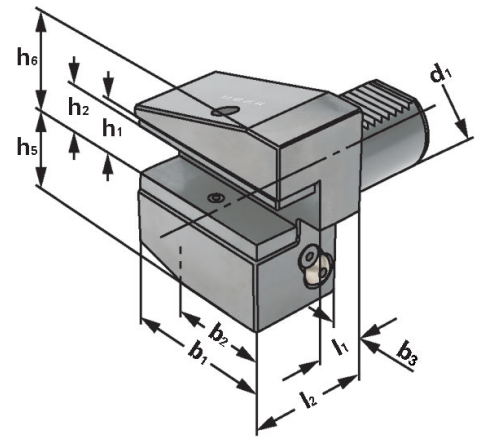

ISO 10889  
DIN 69880

B3

Bestell-Nr. Order no. Référence	Abmessung Size Dimension	d <sub>1</sub>	h <sub>1</sub>	h <sub>2</sub>	l <sub>2</sub>	l <sub>1</sub>	b <sub>1</sub>	b <sub>2</sub>	b <sub>3</sub>	h <sub>5</sub>	h <sub>6</sub>
169.33.12	B3 - 16 × 12 × 24	16	12	-	24	13	42	23	5	20	22
209.33.16	B3 - 20 × 16 × 30	20	16	12	30	16	55	30	7	25	30
259.33.16	B3 - 25 × 16 × 30	25	16	12	30	16	55	30	7	25	30
309.33.20	B3 - 30 × 20 × 40	30	25	20,5	40	22	70	35	10	30	43
409.33.25	B3 - 40 × 25 × 44	40	29	23	44	22	85	42,5	12,5	39,5	51
509.33.32	B3 - 50 × 32 × 55	50	34	26	55	30	100	50	16	49	61

**Ausführung:** Mit einstellbarer Kugelspritzdüse und Unterlegplatte  
**Version:** With adjustable spray nozzle and shim  
**Version:** Avec gicleur ajustable et semelle





Radial toolholders form B3 overhead right, short - for tools with internal coolant  
 Porte-outils radials forme B3 inversés droite, court - pour outils avec arrosage interne



**Verwendung:**  
 Vorwiegend für Außenbearbeitung.  
 Zum Plan Einstechen.

**Application:**  
 Mainly for external machining.  
 For face machining.

**Application:**  
 Principalement pour usinage extérieur.  
 Pour carottage.

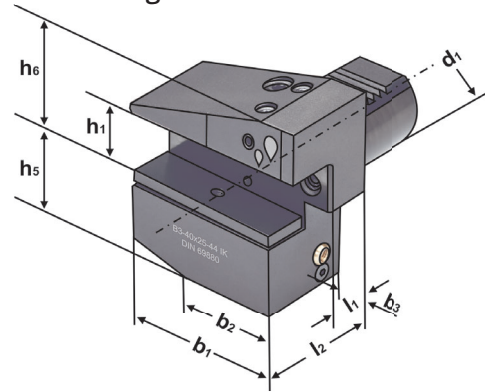

ISO 10889  
 DIN 69880

B3

IC

Bestell-Nr. Order no. Référence	Abmessung Size Dimension	d1	h1	l2	l1	b1	b2	b3	h5	h6
309.33.20.IK	B3 - 30 × 20 × 40	30	20	40	22	70	35	10	35	38
409.33.25.IK	B3 - 40 × 25 × 44	40	25	44	22	85	42,5	12,5	42,5	48
509.33.32.IK	B3 - 50 × 32 × 55	50	32	55	30	100	50	16	50	60

**Ausführung:** Mit einstellbarer Kugelspritzdüse  
**Version:** With adjustable spray nozzle  
**Version:** Avec gicleur ajustable

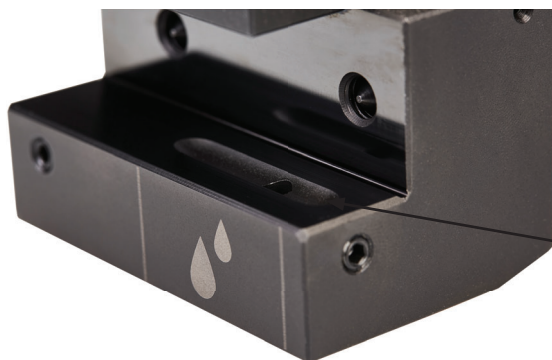

Übergabe für Kühlmittel  
 Coolant supply  
 Jonction d'arrosage

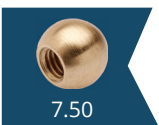



**Verwendung:**  
Vorwiegend für Außenbearbeitung.  
Zum Plan Einstechen.

**Application:**  
Mainly for external machining.  
For face machining.

**Application:**  
Principalement pour usinage extérieur.  
Pour carottage.

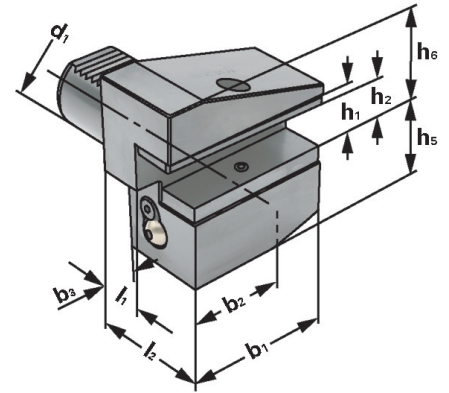

ISO 10889  
DIN 69880

B4

Bestell-Nr. Order no. Référence	Abmessung Size Dimension	d <sub>1</sub>	h <sub>1</sub>	h <sub>2</sub>	l <sub>2</sub>	l <sub>1</sub>	b <sub>1</sub>	b <sub>2</sub>	b <sub>3</sub>	h <sub>5</sub>	h <sub>6</sub>
169.34.12	B4 - 16 × 12 × 24	16	12	-	24	13	42	23	5	20	22
209.34.16	B4 - 20 × 16 × 30	20	16	12	30	16	55	30	7	35	30
259.34.16	B4 - 25 × 16 × 30	25	16	12	30	16	55	30	7	35	30
309.34.20	B4 - 30 × 20 × 40	30	25	20,5	40	22	70	35	10	30	42,5
409.34.25	B4 - 40 × 25 × 44	40	29	23	44	22	85	42,5	12,5	39,5	51
509.34.32	B4 - 50 × 32 × 55	50	34	26	55	30	100	50	16	49	61



**Ausführung:** Mit einstellbarer Kugelspritzdüse und Unterlegplatte  
**Version:** With adjustable spray nozzle and shim  
**Version:** Avec gicleur ajustable et semelle





Radial toolholders form B4 overhead left, short - for tools with internal coolant

Porte-outils radials forme B4 inversés gauche, court - pour outils avec arrosage interne



**Verwendung:**  
Vorwiegend für Außenbearbeitung.  
Zum Plan Einstechen.

**Application:**  
Mainly for external machining.  
For face machining.

**Application:**  
Principalement pour usinage extérieur.  
Pour carottage.

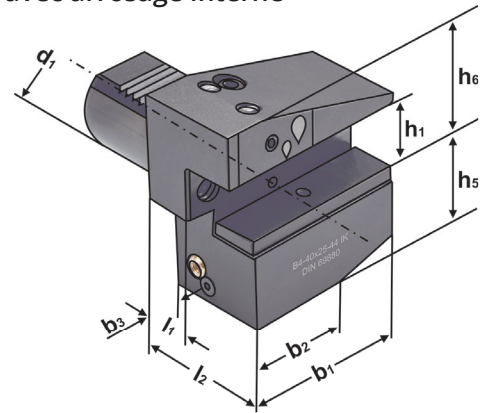

ISO 10889  
DIN 69880

B4

IC

Bestell-Nr. Order no. Référence	Abmessung Size Dimension	d1	h1	l2	l1	b1	b2	b3	h5	h6
309.34.20.IK	B4 - 30 × 20 × 40	30	20	40	22	70	35	10	35	38
409.34.25.IK	B4 - 40 × 25 × 44	40	25	44	22	85	42,5	12,5	42,5	48
509.34.32.IK	B4 - 50 × 32 × 55	50	32	55	30	100	50	16	50	60

**Ausführung:** Mit einstellbarer Kugelspritzdüse  
**Version:** With adjustable spray nozzle  
**Version:** Avec gicleur ajustable

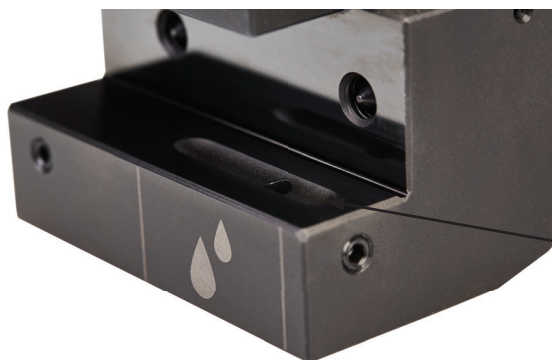

Übergabe für Kühlmittel  
Coolant supply  
Jonction d'arrosage

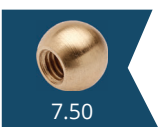



**Verwendung:**  
Vorwiegend für Außenbearbeitung.  
Zum Plan Einstechen.

**Application:**  
Mainly for external machining.  
For face machining.

**Application:**  
Principalement pour usinage extérieur.  
Pour carottage.

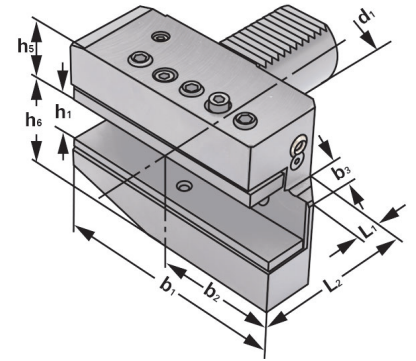

ISO 10889  
DIN 69880

B5

Bestell-Nr. Order no. Référence	Abmessung Size Dimension	d <sub>1</sub>	b <sub>1</sub>	b <sub>2</sub>	b <sub>3</sub>	L <sub>1</sub>	L <sub>2</sub>	h <sub>1</sub>	h <sub>5</sub>	h <sub>6</sub>
169.35.12	B5 - 16 × 12 × 24	16	58	39	5	13	24	12	22	20
209.35.16	B5 - 20 × 16 × 30	20	75	50	7	16	30	16	25	30
259.35.16	B5 - 25 × 16 × 30	25	75	50	7	16	30	16	25	30
309.35.20	B5 - 30 × 20 × 40	30	100	65	10	22	40	20	28	38
409.35.25	B5 - 40 × 25 × 44	40	118	75,5	12,5	22	44	25	32,5	48
509.35.32	B5 - 50 × 32 × 55	50	130	85	16	30	55	32	35	60

**Ausführung:** Mit einstellbarer Kugelspritzdüse und Unterlegplatte  
**Version:** With adjustable spray nozzle and shim  
**Version:** Avec gicleur ajustable et semelle

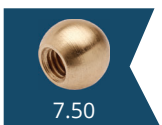



Radial toolholders form B6 left, long  
 Porte-outils radials forme B6 gauche, long

DIN 69880 (VDI 3425)



**Verwendung:**  
 Vorwiegend für Außenbearbeitung.  
 Zum Plan Einstechen.

**Application:**  
 Mainly for external machining.  
 For face machining.

**Application:**  
 Principalement pour usinage extérieur.  
 Pour carottage.

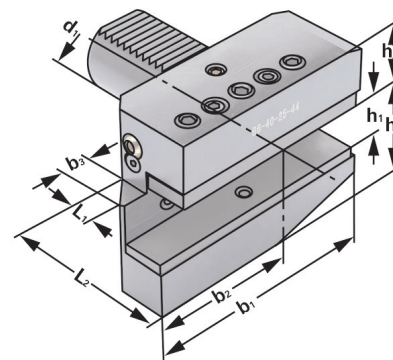

ISO 10889  
 DIN 69880

B6

Bestell-Nr. Order no. Référence	Abmessung Size Dimension	d <sub>1</sub>	b <sub>1</sub>	b <sub>2</sub>	b <sub>3</sub>	L <sub>1</sub>	L <sub>2</sub>	h <sub>1</sub>	h <sub>5</sub>	h <sub>6</sub>
169.36.12	B6 - 16 × 12 × 24	16	58	39	5	13	24	12	22	20
209.36.16	B6 - 20 × 16 × 30	20	75	50	7	16	30	16	25	30
259.35.16	B6 - 25 × 16 × 30	25	75	50	7	16	30	16	25	30
309.36.20	B6 - 30 × 20 × 40	30	100	65	10	22	40	20	28	38
409.36.25	B6 - 40 × 25 × 44	40	118	75,5	12,5	22	44	25	32,5	48
509.36.32	B6 - 50 × 32 × 55	50	130	80	16	30	55	32	35	60

**Ausführung:** Mit einstellbarer Kugelspritzdüse und Unterlegplatte  
**Version:** With adjustable spray nozzle and shim  
**Version:** Avec gicleur ajustable et semelle

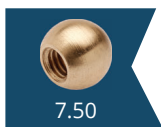



**Verwendung:**  
Vorwiegend für Außenbearbeitung.  
Zum Plan Einstechen.

**Application:**  
Mainly for external machining.  
For face machining.

**Application:**  
Principalement pour usinage extérieur.  
Pour carottage.

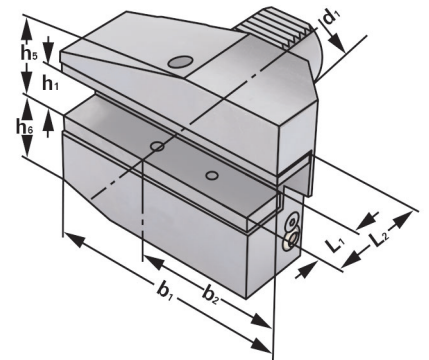

ISO 10889  
DIN 69880

B7

Bestell-Nr. Order no. Référence	Abmessung Size Dimension	d <sub>1</sub>	b <sub>1</sub>	b <sub>2</sub>	b <sub>3</sub>	L <sub>1</sub>	L <sub>2</sub>	h <sub>1</sub>	h <sub>5</sub>	h <sub>6</sub>
169.37.12	B7 - 16 × 12 × 24	16	58	39	5	13	24	12	20	22
209.37.16	B7 - 20 × 16 × 30	20	75	50	7	16	30	16	30	25
259.37.16	B7 - 25 × 16 × 30	25	75	50	7	16	30	16	30	25
309.37.20	B7 - 30 × 20 × 40	30	100	65	10	22	40	20	42	30
409.37.25	B7 - 40 × 25 × 44	40	118	75,5	12,5	22	44	25	48	42,5
509.37.32	B7 - 50 × 32 × 55	50	130	80	16	30	55	32	60	50

**Ausführung:** Mit einstellbarer Kugelspritzdüse und Unterlegplatte  
**Version:** With adjustable spray nozzle and shim  
**Version:** Avec gicleur ajustable et semelle

7

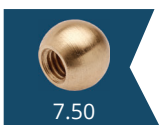

7.50



Radial toolholders form B8 overhead left, long  
 Porte-outils radials forme B8 inversé gauche, long

DIN 69880 (VDI 3425)



**Verwendung:**  
 Vorwiegend für Außenbearbeitung.  
 Zum Plan Einstechen.

**Application:**  
 Mainly for external machining.  
 For face machining.

**Application:**  
 Principalement pour usinage extérieur.  
 Pour carottage.

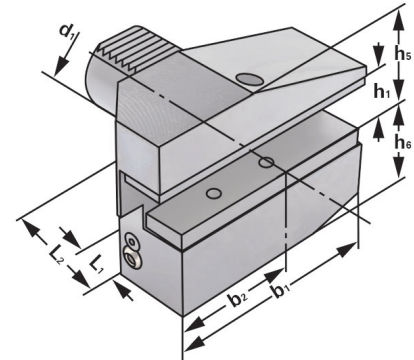

ISO 10889  
 DIN 69880

B8

Bestell-Nr. Order no. Référence	Abmessung Size Dimension	d <sub>1</sub>	b <sub>1</sub>	b <sub>2</sub>	b <sub>3</sub>	L <sub>1</sub>	L <sub>2</sub>	h <sub>1</sub>	h <sub>5</sub>	h <sub>6</sub>
169.38.12	B8 - 16 × 12 × 24	16	58	39	5	13	24	12	20	22
209.38.16	B8 - 20 × 16 × 30	20	75	50	7	16	30	16	30	25
259.38.16	B8 - 25 × 16 × 30	25	75	50	7	16	30	16	30	25
309.38.20	B8 - 30 × 20 × 40	30	100	65	10	22	40	20	38	35
409.38.25	B8 - 40 × 25 × 44	40	118	75,5	12,5	22	44	25	48	42,5
509.38.32	B8 - 50 × 32 × 55	50	130	80	16	30	55	32	60	50



**Ausführung:** Mit einstellbarer Kugelspritzdüse und Unterlegplatte  
**Version:** With adjustable spray nozzle and shim  
**Version:** Avec gicleur ajustable et semelle

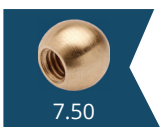





**Verwendung:**  
 Vorwiegend für Außenbearbeitung.  
 Zum Plan Einstechen.

**Application:**  
 Mainly for external machining.  
 For face machining.

**Application:**  
 Principalement pour usinage extérieur.  
 Pour carottage.

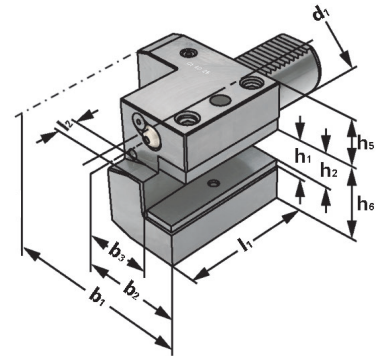

ISO 10889  
 DIN 69880

**C1**

Bestell-Nr. Order no. Référence	Abmessung Size Dimension	d <sub>1</sub>	h <sub>1</sub>	h <sub>2</sub>	b <sub>1</sub>	b <sub>2</sub>	b <sub>3</sub>	l <sub>1</sub>	l <sub>2</sub>	h <sub>5</sub>	h <sub>6</sub>
169.41.12	C1 – 16 × 12	16	12	10	43	24	13	44	5	20	22
209.41.16	C1 – 20 × 16	20	16	12	52	27	13	50	7	25	30
259.41.16	C1 – 25 × 16	25	16	12	58	33	19	55	7	25	30
309.41.20	C1 – 30 × 20	30	20	16	70	35	17	70	10	28	38
409.41.25	C1 – 40 × 25	40	25	20	85	42,5	21	85	12,5	32,5	48
509.41.32	C1 – 50 × 32	50	32	25	100	50	26	100	16	35	60



**Ausführung:** Mit einstellbarer Kugelspritzdüse und Unterlegplatte  
**Version:** With adjustable spray nozzle and shim  
**Version:** Avec gicleur ajustable et semelle

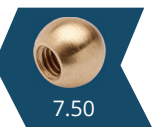
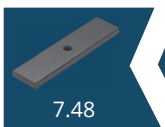



*Axial toolholders form C1 right - for tools with internal coolant*  
 Porte-outils axials forme C1 droite - pour outils avec arrosage interne



**Verwendung:**  
 Vorwiegend für Außenbearbeitung.  
 Zum Plan Einstechen.

**Application:**  
 Mainly for external machining.  
 For face machining.

**Application:**  
 Principalement pour usinage extérieur.  
 Pour carottage.

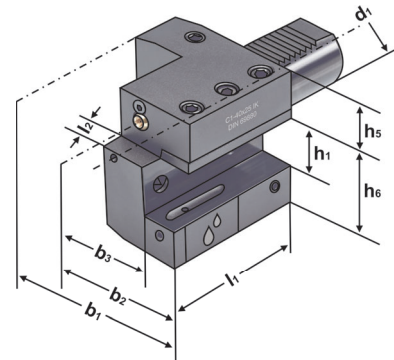

ISO 10889  
 DIN 69880

C1

IC

Bestell-Nr. Order no. Référence	Abmessung Size Dimension	d1	h1	b1	b2	b3	l1	l2	h5	h6
309.41.20.IK	C1 - 30 × 20	30	20	76	49	31	70	10	24	42
409.41.25.IK	C1 - 40 × 25	40	25	90	55	33	85	12,5	32,5	48
509.41.32.IK	C1 - 50 × 32	50	32	105	62	38	100	16	35	60

**Ausführung:** Mit einstellbarer Kugelspritzdüse  
**Version:** With adjustable spray nozzle  
**Version:** Avec gicleur ajustable

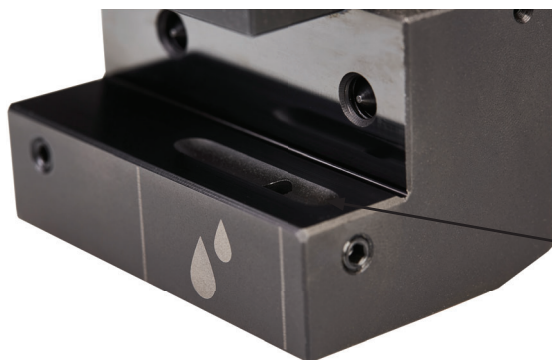

Übergabe für Kühlmittel  
 Coolant supply  
 Jonction d'arrosage

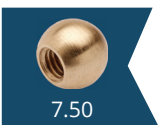



**Verwendung:**  
Vorwiegend für Außenbearbeitung.  
Zum Plan Einstechen.

**Application:**  
Mainly for external machining.  
For face machining.

**Application:**  
Principalement pour usinage extérieur.  
Pour carottage.

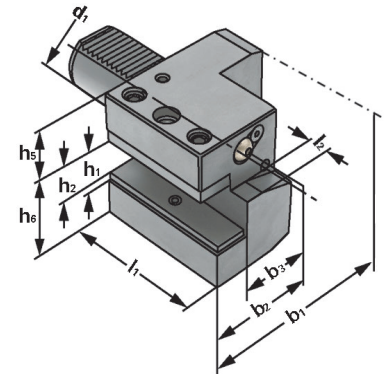

ISO 10889  
DIN 69880

C2

Bestell-Nr. Order no. Référence	Abmessung Size Dimension	d <sub>1</sub>	h <sub>1</sub>	h <sub>2</sub>	b <sub>1</sub>	b <sub>2</sub>	b <sub>3</sub>	l <sub>1</sub>	l <sub>2</sub>	h <sub>5</sub>	h <sub>6</sub>
169.42.12	C2 - 16 × 12	16	12	-	43	24	13	44	5	20	22
209.42.16	C2 - 20 × 16	20	16	12	65	40	26	50	7	25	30
259.42.16	C2 - 25 × 16	25	16	12	58	33	26	55	7	20	30
309.42.20	C2 - 30 × 20	30	20	16	76	41	23	70	10	28	38
409.42.25	C2 - 40 × 25	40	25	20	90	47,5	25,5	85	12,5	32,5	48
509.42.32	C2 - 50 × 32	50	32	25	105	55	30,5	100	16	35	60



**Ausführung:** Mit einstellbarer Kugelspritzdüse und Unterlegplatte  
**Version:** With adjustable spray nozzle and shim  
**Version:** Avec gicleur ajustable et semelle

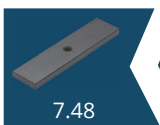

für Werkzeuge mit Innenkühlung

DIN 69880 (VDI 3425)

Axial toolholders form C2 left - for tools with internal coolant  
 Porte-outils axials forme C2 gauche - pour outils avec arrosage interne



**Verwendung:**  
 Vorwiegend für Außenbearbeitung.  
 Zum Plan Einstechen.

**Application:**  
 Mainly for external machining.  
 For face machining.

**Application:**  
 Principalement pour usinage extérieur.  
 Pour carottage.

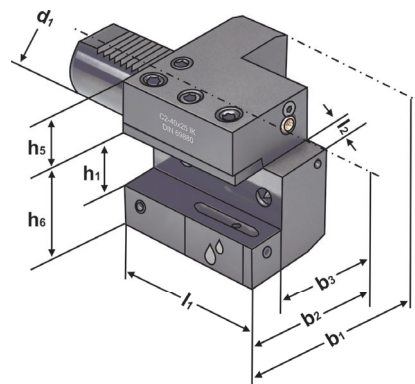

ISO 10889  
 DIN 69880

C2

IC

Bestell-Nr. Order no. Référence	Abmessung Size Dimension	d1	h1	b1	b2	b3	l1	l2	h5	h6
309.42.20.IK	C2 - 30 × 20	30	20	76	49	31	70	10	24	42
409.42.25.IK	C2 - 40 × 25	40	25	90	55	33	85	12,5	32,5	48
509.42.32.IK	C2 - 50 × 32	50	32	105	62	38	100	16	35	60

**Ausführung:** Mit einstellbarer Kugelspritzdüse  
**Version:** With adjustable spray nozzle  
**Version:** Avec gicleur ajustable

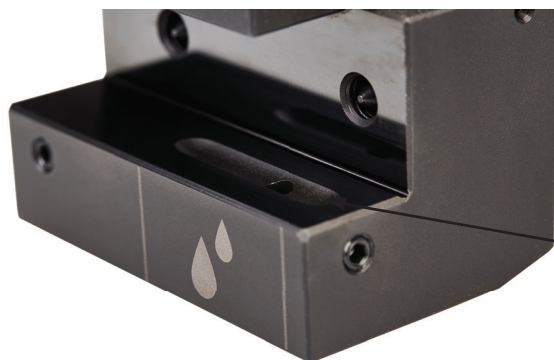

Übergabe für Kühlmittel  
 Coolant supply  
 Jonction d'arrosage

7.48

7.50



**Verwendung:**  
Vorwiegend für Außenbearbeitung.  
Zum Plan Einstechen.

**Application:**  
Mainly for external machining.  
For face machining.

**Application:**  
Principalement pour usinage extérieur.  
Pour carottage.

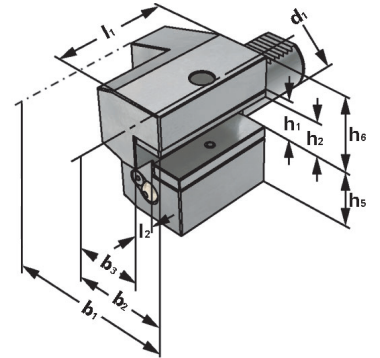

ISO 10889  
DIN 69880

C3

Bestell-Nr. Order no. Référence	Abmessung Size Dimension	d <sub>1</sub>	h <sub>1</sub>	h <sub>2</sub>	b <sub>1</sub>	b <sub>2</sub>	b <sub>3</sub>	l <sub>1</sub>	l <sub>2</sub>	h <sub>5</sub>	h <sub>6</sub>
169.43.12	C3 - 16 × 12	16	12	10	43	24	13	44	5	20	22
209.43.16	C3 - 20 × 16	20	16	12	52	27	13	55	7	30	25
259.43.16	C3 - 25 × 16	25	16	12	58	33	19	55	7	30	25
309.43.20	C3 - 30 × 20	30	20	16	70	35	17	70	10	38	35
409.43.25	C3 - 40 × 25	40	25	20	85	42,5	21	85	12,5	48	42,5
509.43.32	C3 - 50 × 32	50	32	25	100	50	26	100	16	60	50

**Ausführung:** Mit einstellbarer Kugelspritzdüse und Unterlegplatte  
**Version:** With adjustable spray nozzle and shim  
**Version:** Avec gicleur ajustable et semelle

7





*Axial toolholders form C3 overhead right - for tools with internal coolant*  
 Porte-outils axials forme C3 inversés droite - pour outils avec arrosage interne



**Verwendung:**  
 Vorwiegend für Außenbearbeitung.  
 Zum Plan Einstechen.

**Application:**  
 Mainly for external machining.  
 For face machining.

**Application:**  
 Principalement pour usinage extérieur.  
 Pour carottage.

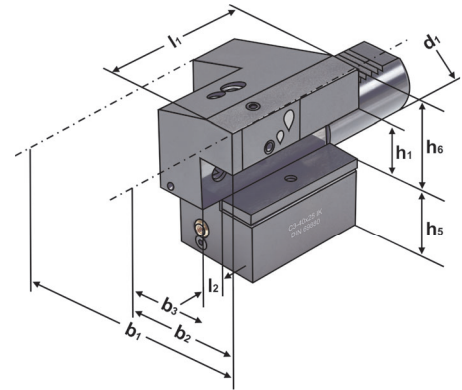

Bestell-Nr. Order no. Référence	Abmessung Size Dimension	d1	h1	b1	b2	b3	l1	l2	h5	h6
309.43.20.IK	C3 - 30 × 20	30	20	70	35	17	70	10	38	35
409.43.25.IK	C3 - 40 × 25	40	25	85	42,5	21	85	12,5	48	42,5
509.43.32.IK	C3 - 50 × 32	50	32	100	50	26	100	16	60	50

**Ausführung:** Mit einstellbarer Kugelspritzdüse  
**Version:** With adjustable spray nozzle  
**Version:** Avec gicleur ajustable

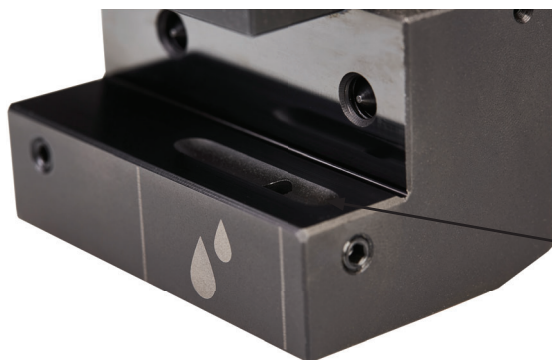

Übergabe für Kühlmittel  
 Coolant supply  
 Jonction d'arrosage

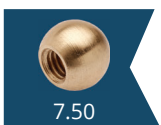



**Verwendung:**  
Vorwiegend für Außenbearbeitung.  
Zum Plan Einstechen.

**Application:**  
Mainly for external machining.  
For face machining.

**Application:**  
Principalement pour usinage extérieur.  
Pour carottage.

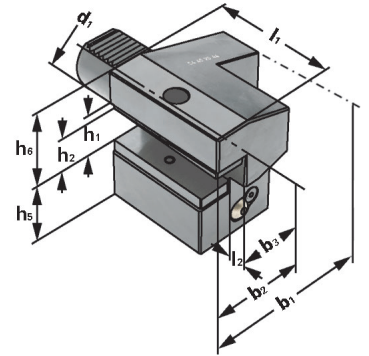

ISO 10889  
DIN 69880

C4

Bestell-Nr. Order no. Référence	Abmessung Size Dimension	d <sub>1</sub>	h <sub>1</sub>	h <sub>2</sub>	b <sub>1</sub>	b <sub>2</sub>	b <sub>3</sub>	l <sub>1</sub>	l <sub>2</sub>	h <sub>5</sub>	h <sub>6</sub>
169.44.12	C4 - 16 × 12	16	12	10	43	24	13	44	5	22	20
209.44.16	C4 - 20 × 16	20	16	12	65	40	26	50	7	30	25
259.44.16	C4 - 25 × 16	25	16	12	58	33	19	55	7	30	25
309.44.20	C4 - 30 × 20	30	20	16	76	41	23	70	10	38	35
409.44.25	C4 - 40 × 25	40	25	20	90	47,5	25,5	85	12,5	48	42,5
509.44.32	C4 - 50 × 32	50	32	25	105	55	30,5	100	16	60	50

7

**Ausführung:** Mit einstellbarer Kugelspritzdüse und Unterlegplatte  
**Version:** With adjustable spray nozzle and shim  
**Version:** Avec gicleur ajustable et semelle





*Axial toolholders form C4 overhead left - for tools with internal coolant*  
 Porte-outils axials forme C4 inversés gauche - pour outils avec arrosage interne



**Verwendung:**  
 Vorwiegend für Außenbearbeitung.  
 Zum Plan Einstechen.

**Application:**  
 Mainly for external machining.  
 For face machining.

**Application:**  
 Principalement pour usinage extérieur.  
 Pour carottage.

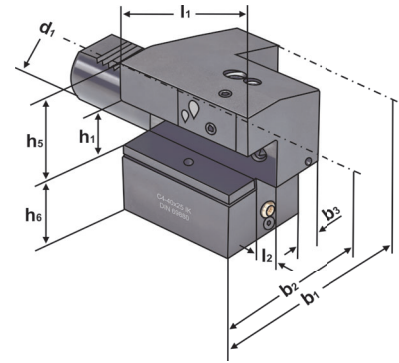

ISO 10889  
 DIN 69880

C4

IC

Bestell-Nr. Order no. Référence	Abmessung Size Dimension	d1	h1	b1	b2	b3	l1	l2	h5	h6
309.44.20.IK	C4 - 30 × 20	30	20	70	35	17	70	10	38	35
409.44.25.IK	C4 - 40 × 25	40	25	85	42,5	21	85	12,5	48	42,5
509.44.32.IK	C4 - 50 × 32	50	32	100	50	26	100	16	60	50

**Ausführung:** Mit einstellbarer Kugelspritzdüse  
**Version:** With adjustable spray nozzle  
**Version:** Avec gicleur ajustable

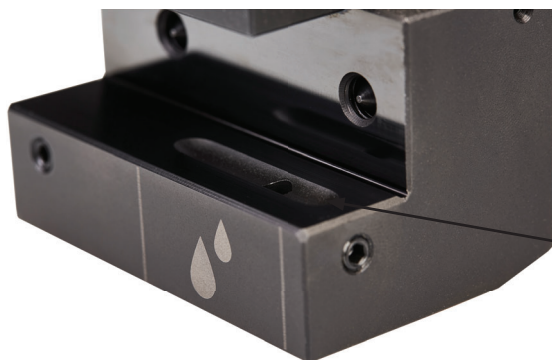

Übergabe für Kühlmittel  
 Coolant supply  
 Jonction d'arrosage

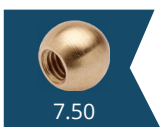





**Verwendung:**  
Vorwiegend für Außenbearbeitung.  
Zum Plan Einstechen.

**Application:**  
Mainly for external machining.  
For face machining.

**Application:**  
Principalement pour usinage extérieur.  
Pour carottage.

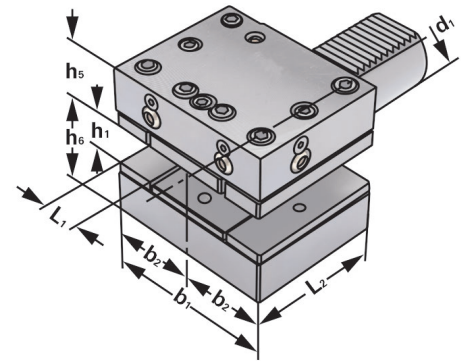

ISO 10889  
DIN 69880

D1

Bestell-Nr. Order no. Référence	Abmessung Size Dimension	d <sub>1</sub>	b <sub>1</sub>	b <sub>2</sub>	L <sub>1</sub>	L <sub>2</sub>	h <sub>1</sub>	h <sub>5</sub>	h <sub>6</sub>
309.89.12	D1 - 30 × 20 × 60	30	76	41	18	60	20	28	38
409.89.16	D1 - 40 × 25 × 72	40	90	47,5	22	72	25	32,5	48
509.89.20	D1 - 50 × 32 × 85	50	105	55	24,5	85	32	35	60

**Ausführung:** Mit einstellbarer Kugelspritzdüse und Unterlegplatte  
**Version:** With adjustable spray nozzle and shim  
**Version:** Avec gicleur ajustable et semelle

7

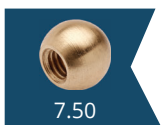



Rectangular toolholders with multiple seats, overhead form D2  
 Porte-outils, multiple, inversés forme D2

DIN 69880 (VDI 3425)



**Verwendung:**  
 Vorwiegend für Außenbearbeitung.  
 Zum Plan Einstechen.

**Application:**  
 Mainly for external machining.  
 For face machining.

**Application:**  
 Principalement pour usinage extérieur.  
 Pour carottage.

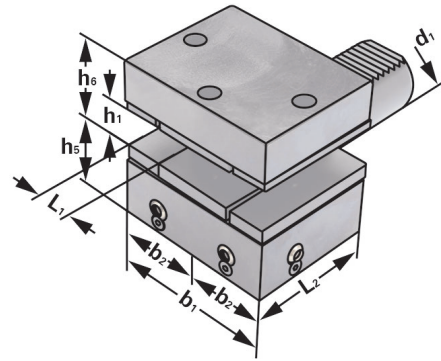

ISO 10889  
 DIN 69880

D2

Bestell-Nr. Order no. Référence	Abmessung Size Dimension	d <sub>1</sub>	b <sub>1</sub>	b <sub>2</sub>	L <sub>1</sub>	L <sub>2</sub>	h <sub>1</sub>	h <sub>2</sub>	h <sub>5</sub>	h <sub>6</sub>
309.90.12	D2 – 30 × 20 × 60	30	76	41	18	60	20	73	35	38
409.90.16	D2 – 40 × 25 × 72	40	90	47,5	22	72	25	90,5	42,5	48
509.90.20	D2 – 50 × 32 × 85	50	105	55	24,5	85	32	110	50	60

**Ausführung:** Mit einstellbarer Kugelspritzdüse und Unterlegplatte  
**Version:** With adjustable spray nozzle and shim  
**Version:** Avec gicleur ajustable et semelle

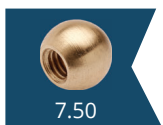



**Verwendung:**  
Vorwiegend für Außenbearbeitung.  
Zum Plan Einstechen.

**Application:**  
Mainly for external machining.  
For face machining.

**Application:**  
Principalement pour usinage extérieur.  
Pour carottage.

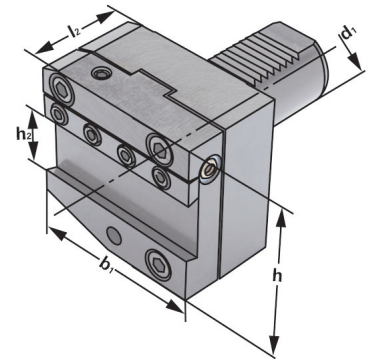

ISO 10889  
DIN 69880

AR

Bestell-Nr. Order no. Référence	Abmessung Size Dimension	d <sub>1</sub>	b <sub>1</sub>	h	l <sub>2</sub>	h <sub>2</sub>
309.65.26	AR - 30 × 26	30	70	70	50	26
409.65.32	AR - 40 × 32	40	85	80	50	32
509.65.32	AR - 50 × 32	50	100	80	50	32

**Ausführung:** Mit einstellbarer Kugelspritzdüse  
**Version:** With adjustable spray nozzle  
**Version:** Avec gicleur ajustable

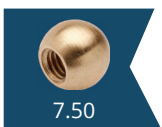



Parting-off toolholders left height adjustable  
 Porte-lames de tronçonnage gauche réglage en hauteur

DIN 69880 (VDI 3425)



**Verwendung:**  
 Vorwiegend für Außenbearbeitung.  
 Zum Plan Einstechen.

**Application:**  
 Mainly for external machining.  
 For face machining.

**Application:**  
 Principalement pour usinage extérieur.  
 Pour carottage.

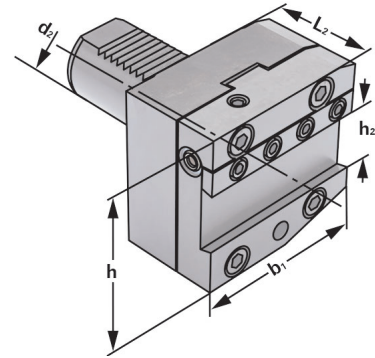

ISO 10889  
 DIN 69880

AL

Bestell-Nr. Order no. Référence	Abmessung Size Dimension	d <sub>1</sub>	b <sub>1</sub>	h	l <sub>2</sub>	h <sub>2</sub>
309.66.26	AL - 30 × 26	30	70	70	50	26
409.66.32	AL - 40 × 32	40	85	80	50	32
509.66.32	AL - 50 × 32	50	100	80	50	32

**Ausführung:** Mit einstellbarer Kugelspritzdüse  
**Version:** With adjustable spray nozzle  
**Version:** Avec gicleur ajustable

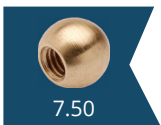



Collet chucks form E3 DIN 6391 for collets DIN 6388 (ISO 10897) OZ-system  
Mandrins à pinces forme E3 DIN 6391 pour pinces DIN 6388 (ISO 10897) système OZ

**Verwendung:**

Zur Aufnahme von Werkzeugen mit Zylinderschaft in Spannzangen.

**Application:**

For mounting straight-shank tools in collets.

**Application:**

Pour le serrage d'outils avec queue cylindrique dans des pinces de serrage.

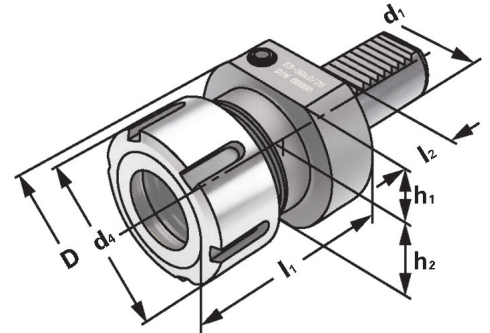
ISO 10889  
DIN 69880

E3



Bestell-Nr. Order no. Référence	Abmessung Size Dimension	d <sub>1</sub>	Spannbereich Capacity Capacité	D	d <sub>4</sub>	h <sub>1</sub>	h <sub>2</sub>	l <sub>1</sub>	l <sub>2</sub>
169.01.16	E3 - 16 × 2 - 16	16	2 - 16 (OZ 16)	40	43	18	18	45,5	13
209.01.16	E3 - 20 × 2 - 16	20	2 - 16 (OZ 16)	50	43	25	23	57	18
259.01.16	E3 - 25 × 2 - 16	25	2 - 16 (OZ 16)	58	43	25	25	57	18
309.01.16	E3 - 30 × 2 - 16	30	2 - 16 (OZ 16)	68	43	28	30	57	22
309.01.25	E3 - 30 × 2 - 25	30	2 - 25 (OZ 25)	68	60	28	30	75	22
409.01.25	E3 - 40 × 2 - 25	40	2 - 25 (OZ 25)	83	60	32,5	41,5	75	22
409.01.32	E3 - 40 × 3 - 32	40	3 - 32 (OZ 32)	83	72	32,5	41,5	90	22
509.01.25	E3 - 50 × 2 - 25	50	2 - 25 (OZ 25)	98	60	35	49	75	30
509.01.32	E3 - 50 × 3 - 32	50	3 - 32 (OZ 32)	98	72	35	49	90	30

**Lieferumfang:** Mit kugellagerter Spannmutter  
**Delivery:** With ball bearing clamping nut  
**Livraison:** Avec écrou de serrage à roulement à billes



Collet chucks form E4 for collets DIN 6499 (ISO 15488) ER-system

Mandrins à pinces forme E4 pour pinces DIN 6499 (ISO 15488) système ER



**Verwendung:**  
Zur Aufnahme von Werkzeugen mit  
Zylinderschaft in Spannzangen.

**Application:**  
For mounting straight-shank tools in  
collets.

**Application:**  
Pour le serrage d'outils avec queue  
cylindrique dans des pinces de serrage.

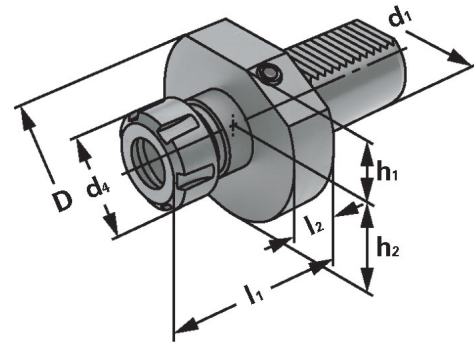

ISO 10889  
DIN 69880

E4



Bestell-Nr. Order no. Référence	Abmessung Size Dimension	d <sub>1</sub>	Spannbereich Capacity Capacité	D	d <sub>4</sub>	h <sub>1</sub>	h <sub>2</sub>	l <sub>1</sub>	l <sub>2</sub>
169.02.10	E4 - 16 × 1 - 10	16	1 - 10 (ER 16)	40	28	18	18	40	13
209.02.10	E4 - 20 × 1 - 10	20	1 - 10 (ER 16)	50	28	25	23	42	18
209.02.16	E4 - 20 × 2 - 16	20	2 - 16 (ER 25)	50	42	25	23	46	18
259.02.16	E4 - 25 × 2 - 16	25	2 - 16 (ER 25)	58	42	25	25	55	18
259.02.20	E4 - 25 × 2 - 20	25	2 - 20 (ER 32)	58	50	25	25	55	18
309.02.16	E4 - 30 × 2 - 16	30	2 - 16 (ER 25)	68	42	28	30	57	22
309.02.20	E4 - 30 × 2 - 20	30	2 - 20 (ER 32)	68	50	28	30	75	22
309.02.26	E4 - 30 × 3 - 26	30	3 - 26 (ER 40)	68	63	28	30	75	22
409.02.16	E4 - 40 × 2 - 16	40	2 - 16 (ER 25)	83	42	32,5	41,5	75	22
409.02.20	E4 - 40 × 2 - 20	40	2 - 20 (ER 32)	83	50	32,5	41,5	75	22
409.02.26	E4 - 40 × 3 - 26	40	3 - 26 (ER 40)	83	63	32,5	41,5	75	22
509.02.26	E4 - 50 × 3 - 26	50	3 - 26 (ER 40)	98	63	35	49	75	30

**Lieferumfang:** Mit gewuchteter Spannmutter  
**Delivery:** With balanced clamping nut  
**Livraison:** Avec écrou de serrage équilibré





**Verwendung:**  
Zur Aufnahme von allen nach DIN 6595 genormten Vollbohrern mit Zylinderschaft.

**Application:**  
For all solid drills with cylindrical shank according to DIN 6595.

**Application:**  
Pour le serrage de forets à queue cylindrique suivant DIN 6595.

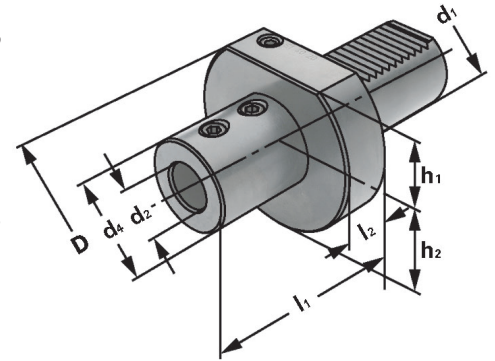
ISO 10889  
DIN 69880

E1

Bestell-Nr. Order no. Référence	Abmessung Size Dimension	d <sub>1</sub>	d <sub>2</sub>	d <sub>4</sub>	D	h <sub>1</sub>	h <sub>2</sub>	l <sub>1</sub>	l <sub>2</sub>
209.51.16	E1 - 20 × 16	20	16	40	50	22	22	67	18
209.51.20	E1 - 20 × 20	20	20	40	50	22	22	67	18
209.51.25	E1 - 20 × 25	20	25	45	50	22	22	71	18
259.51.16	E1 - 25 × 16	25	16	40	58	25	25	67	18
259.51.20	E1 - 25 × 20	25	20	40	58	25	25	67	18
259.51.25	E1 - 25 × 25	25	25	45	58	25	25	71	18
259.51.32	E1 - 25 × 32	25	32	58	58	25	25	78	-
309.51.16	E1 - 30 × 16	30	16	36	68	28	30	64	22
309.51.20	E1 - 30 × 20	30	20	40	68	28	30	67	22
309.51.25	E1 - 30 × 25	30	25	45	68	28	30	71	22
309.51.32	E1 - 30 × 32	30	32	52	68	28	30	75	22
309.51.40	E1 - 30 × 40	30	40	60	68	28	30	95	22
409.51.16	E1 - 40 × 16	40	16	36	83	32,5	41,5	64	22
409.51.20	E1 - 40 × 20	40	20	40	83	32,5	41,5	67	22
409.51.25	E1 - 40 × 25	40	25	45	83	32,5	41,5	75	22
409.51.32	E1 - 40 × 32	40	32	52	83	32,5	41,5	75	22
409.51.40	E1 - 40 × 40	40	40	65	83	32,5	41,5	90	22
509.51.16	E1 - 50 × 16	50	16	40	98	35	49	66	30
509.51.20	E1 - 50 × 20	50	20	40	98	35	49	66	30
509.51.25	E1 - 50 × 25	50	25	45	98	35	49	80	30
509.51.32	E1 - 50 × 32	50	32	52	98	35	49	80	30
509.51.40	E1 - 50 × 40	50	40	65	98	35	49	90	30
509.51.50	E1 - 50 × 50	50	50	75	98	35	49	100	30

**Lieferumfang:** Mit Spannschrauben  
**Delivery:** With clamping screws  
**Livraison:** Avec vis de serrage

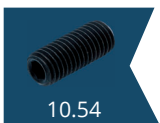

10.54



Drill chuck adaptors DIN 238  
Arbres pour mandrins de perçage DIN 238

DIN 69880 (VDI 3425)



**Verwendung:**  
Zur Aufnahme von Bohrfuttern.  
**Application:**  
For mounting drill chucks.  
**Application:**  
Pour le serrage de mandrins de perçage.

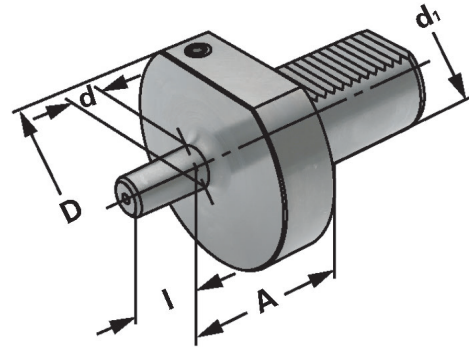

ISO 10889  
DIN 69880

DIN 238

Bestell-Nr. Order no. Référence	Abmessung Size Dimension	d <sub>1</sub>	d	D	A	I
309.14.16	30 - B16	30	B16	68	27	24
409.14.16	40 - B16	40	B16	83	27	24
509.14.16	50 - B16	50	B16	98	35	24







**Verwendung:**  
Für Innenbearbeitung mit Bohrstangen.

**Application:**  
For internal machining with boring bars.

**Application:**  
Pour l'usinage intérieur avec barres d'alésage.

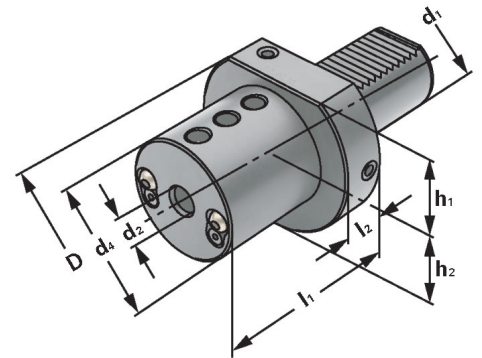

ISO 10889  
DIN 69880

E2

Bestell-Nr. Order no. Référence	Abmessung Size Dimension	d <sub>1</sub>	d <sub>2</sub>	D	d <sub>4</sub>	h <sub>1</sub>	h <sub>2</sub>	l <sub>1</sub>	l <sub>2</sub>
169.52.06	E2 – 16 × 06	16	6	40	32	18	20	44	13
169.52.08	E2 – 16 × 08	16	8	40	32	18	20	44	13
169.52.10	E2 – 16 × 10	16	10	40	32	18	20	44	13
169.52.12	E2 – 16 × 12	16	12	40	32	18	20	44	13
169.52.16	E2 – 16 × 16	16	16	40	32	18	20	44	13
209.52.08	E2 – 20 × 08	20	8	50	40	23	25	50	18
209.52.10	E2 – 20 × 10	20	10	50	40	23	25	50	18
209.52.12	E2 – 20 × 12	20	12	50	40	23	25	50	18
209.52.16	E2 – 20 × 16	20	16	50	40	23	25	50	18
209.52.20	E2 – 20 × 20	20	20	50	40	23	25	50	18
259.52.08	E2 – 25 × 08	25	8	58	40	-	25	50	18
259.52.10	E2 – 25 × 10	25	10	58	40	-	25	50	18
259.52.12	E2 – 25 × 12	25	12	58	40	-	25	50	18
259.52.16	E2 – 25 × 16	25	16	58	40	-	25	50	18
259.52.20	E2 – 25 × 20	25	20	58	58	-	25	50	-
259.52.25	E2 – 25 × 25	25	25	58	58	-	25	60	-



**Ausführung:** Mit einstellbaren Kugelspritzdüsen  
**Version:** With adjustable spray nozzles  
**Version:** Avec gicleurs ajustables

**Lieferumfang:** Mit Spannschrauben  
**Delivery:** With clamping screws  
**Livraison:** Avec vis de serrage



## Boring bar holders form E2

DIN 69880 (VDI 3425)

Porte-outils pour barres d'alésage forme E2



**Verwendung:**  
Für Innenbearbeitung mit Bohrstangen.

**Application:**  
For internal machining with boring bars.

**Application:**  
Pour l'usinage intérieur avec barres d'alésage.

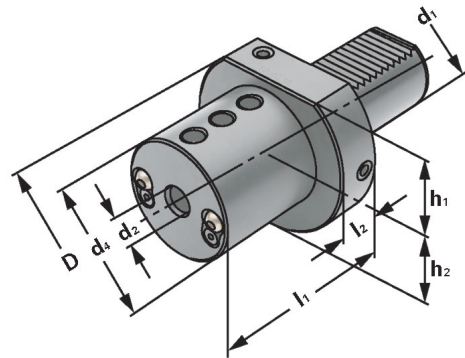
ISO 10889  
DIN 69880

E2

Bestell-Nr. Order no. Référence	Abmessung Size Dimension	d <sub>1</sub>	d <sub>2</sub>	D	d <sub>4</sub>	h <sub>1</sub>	h <sub>2</sub>	l <sub>1</sub>	l <sub>2</sub>
309.52.08	E2 - 30 × 08	30	8	68	55	28	30	60	22
309.52.10	E2 - 30 × 10	30	10	68	55	28	30	60	22
309.52.12	E2 - 30 × 12	30	12	68	55	28	30	60	22
309.52.16	E2 - 30 × 16	30	16	68	55	28	30	60	22
309.52.20	E2 - 30 × 20	30	20	68	55	28	30	60	22
309.52.25	E2 - 30 × 25	30	25	68	55	28	30	60	22
309.52.32	E2 - 30 × 32	30	32	68	68	28	30	75	-
409.52.08	E2 - 40 × 08	40	8	83	55	32,5	41,5	75	22
409.52.10	E2 - 40 × 10	40	10	83	55	32,5	41,5	75	22
409.52.12	E2 - 40 × 12	40	12	83	55	32,5	41,5	75	22
409.52.16	E2 - 40 × 16	40	16	83	55	32,5	41,5	75	22
409.52.20	E2 - 40 × 20	40	20	83	55	32,5	41,5	75	22
409.52.25	E2 - 40 × 25	40	25	83	55	32,5	41,5	75	22
409.52.32	E2 - 40 × 32	40	32	83	83	32,5	41,5	75	-
409.52.40	E2 - 40 × 40	40	40	83	83	32,5	41,5	90	-
509.52.12	E2 - 50 × 12	50	12	98	68	35	49	90	30
509.52.16	E2 - 50 × 16	50	16	98	68	35	49	90	30
509.52.20	E2 - 50 × 20	50	20	98	68	35	49	90	30
509.52.25	E2 - 50 × 25	50	25	98	68	35	49	90	30
509.52.32	E2 - 50 × 32	50	32	98	68	35	49	90	30
509.52.40	E2 - 50 × 40	50	40	98	98	35	49	90	-
509.52.50	E2 - 50 × 50	50	50	98	98	35	49	100	-

**Ausführung:** Mit einstellbaren Kugelspritzdüsen  
**Version:** With adjustable spray nozzles  
**Version:** Avec gicleurs ajustables

**Lieferumfang:** Mit Spannschrauben  
**Delivery:** With clamping screws  
**Livraison:** Avec vis de serrage





Form 1



Form 2

**Verwendung:**  
 Reduzierung zum Spannen von Werkzeugen mit Zylinderschaft, wie z. B. Feindreh-Bohrstangen.

**Application:**  
 Reduction for mounting tools with straight-shank, such as precision boring bars.

**Application:**  
 Réduction pour le serrage d'outils avec queue cylindrique, p. ex. barres d'alésage pour tournage de finition.

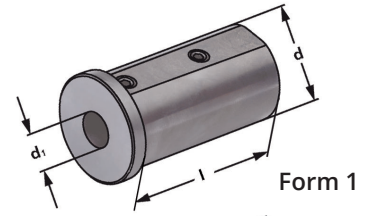

Form 1

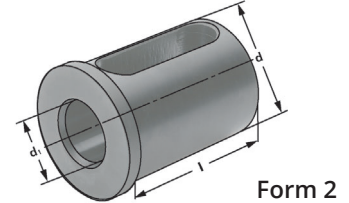

Form 2

Bestell-Nr. Order no. Référence	Form form forme	d	d <sub>1</sub>	l
709.25.06	1	25	6	46
709.25.08	1	25	8	46
709.25.10	1	25	10	46
709.25.12	1	25	12	46
709.25.14	1	25	14	46
709.25.16	2	25	16	46
709.25.18	2	25	18	46
709.25.20	2	25	20	46
709.32.06	1	32	6	56
709.32.08	1	32	8	56
709.32.10	1	32	10	56
709.32.12	1	32	12	56
709.32.14	1	32	14	56
709.32.16	2	32	16	56
709.32.18	2	32	18	56
709.32.20	2	32	20	56
709.32.25	2	32	25	56

**Hinweis:** Geeignet für Innenkühlung (nicht geschlitzt)  
**Note:** Suitable for through-coolant (not slotted)  
**Observation:** Convenable pour arrosage interne (non fendu)



Reduction sleeves for boring bar holders form E2

DIN 69880 (VDI 3425)

Douilles de réduction pour barres d'alésage forme E2



Form 1



Form 2

**Verwendung:**  
Reduzierung zum Spannen von Werkzeugen mit Zylinderschaft, wie z. B. Feindreh-Bohrstangen.

**Application:**  
Reduction for mounting tools with straight-shank, such as precision boring bars.

**Application:**  
Réduction pour le serrage d'outils avec queue cylindrique, p. ex. barres d'alésage pour tournage de finition.

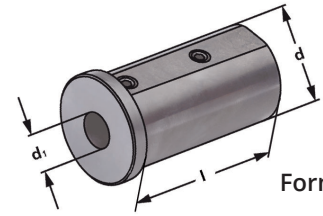

Form 1

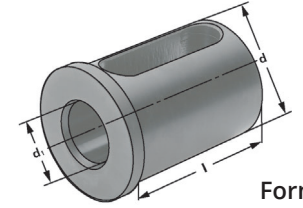

Form 2

Bestell-Nr. Order no. Référence	Form form forme	d	d <sub>1</sub>	l
709.40.06	1	40	6	71
709.40.08	1	40	8	71
709.40.10	1	40	10	71
709.40.12	1	40	12	71
709.40.14	1	40	14	71
709.40.16	2	40	16	71
709.40.18	2	40	18	71
709.40.20	2	40	20	71
709.40.25	2	40	25	71
709.40.32	2	40	32	71

**Hinweis:** Geeignet für Innenkühlung (nicht geschlitzt)  
**Note:** Suitable for through-coolant (not slotted)  
**Observation:** Convenable pour arrosage interne (non fendu)





**Verwendung:**  
Zur Aufnahme von Werkzeugen mit Morsekegelschaft und Austreibblappen nach DIN 228-1 Form B.

**Application:**  
For holding tools with Morse taper shank and tang according to DIN 228-1 form B.

**Application:**  
Pour le serrage d'outils avec queue cône Morse et tenon suivant DIN 228-1 forme B.

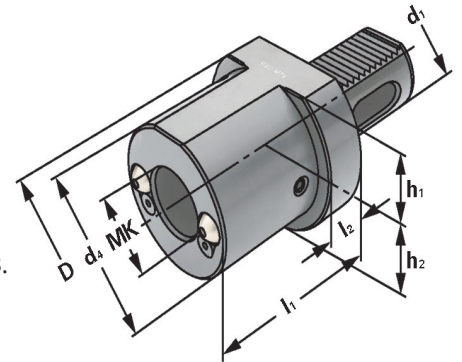

ISO 10889  
DIN 69880

F1

Bestell-Nr. Order no. Référence	Abmessung Size Dimension	d <sub>1</sub>	MK MT CM	d <sub>4</sub>	D	l <sub>1</sub>	l <sub>2</sub>	h <sub>1</sub>	h <sub>2</sub>
169.07.01	F1 - 16 × MK 1	16	1	32	40	32	13	18	18
209.07.01	F1 - 20 × MK 1	20	1	-	50	23	-	22	23
209.07.02	F1 - 20 × MK 2	20	2	40	50	90	-	22	23
259.07.01	F1 - 25 × MK 1	25	1	-	58	23	-	25	25
259.07.02	F1 - 25 × MK 2	25	2	-	58	27	-	25	25
309.07.01	F1 - 30 × MK 1	30	1	-	68	27	-	28	30
309.07.02	F1 - 30 × MK 2	30	2	-	68	27	-	28	30
309.07.03	F1 - 30 × MK 3	30	3	58	68	75	22	28	30
409.07.02	F1 - 40 × MK 2	40	2	55	83	36	22	32,5	50,5
409.07.03	F1 - 40 × MK 3	40	3	55	83	36	22	32,5	50,5
409.07.04	F1 - 40 × MK 4	40	4	68	83	80	22	32,5	50,5
509.07.02	F1 - 50 × MK 2	50	2	55	98	36	30	35	49
509.07.03	F1 - 50 × MK 3	50	3	58	98	36	30	35	49
509.07.04	F1 - 50 × MK 4	50	4	68	98	50	30	35	49
509.07.05	F1 - 50 × MK 5	50	5	98	98	168	-	35	49

**Ausführung:** Mit einstellbaren Kugelspritzdüsen  
**Version:** With adjustable spray nozzles  
**Version:** Avec gicleurs ajustables





**Verwendung:**  
Zur Aufnahme von Werkzeugen mit Zylinderschaft nach DIN 1835 Form A+B+E und DIN 6535 Form HA+HB+HE (größer Ø 20 mm nur mit Reduzierung).

**Application:**  
For mounting straight-shank tools acc. DIN 1835 form A+B+E and DIN 6535 form HA+HB+HE (larger than Ø 20 mm only with reduction sleeve).

**Application:**  
Pour le serrage d'outils avec queue cylindrique suivant DIN 1835 forme A+B+E et DIN 6535 forme HA+HB+HE (à partir de Ø 20 mm seulement avec réduction).

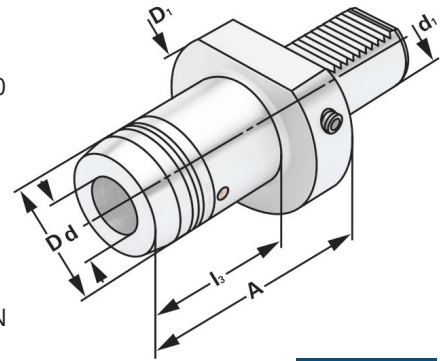

ISO 10889  
DIN 69880

14.04

Bestell-Nr. Order no. Référence	Abmessung Size Dimension	d <sub>1</sub>	d	D	A	l <sub>3</sub>	D <sub>1</sub>
309.H06	30 - 06	30	6	26	49	33	68
309.H08	30 - 08	30	8	28	49	33	68
309.H10	30 - 10	30	10	30	49	33	68
309.H12	30 - 12	30	12	32	54	38	68
309.H14	30 - 14	30	14	34	54	38	68
309.H16	30 - 16	30	16	38	89	73	68
309.H18	30 - 18	30	18	40	89	73	68
309.H20	30 - 20	30	20	42	89	73	68
309.H25	30 - 25	30	25	50	94	78	68
309.H32	30 - 32	30	32	60	94	78	68
409.H06	40 - 06	40	6	26	55	33	83
409.H08	40 - 08	40	8	28	55	33	83
409.H10	40 - 10	40	10	30	55	33	83
409.H12	40 - 12	40	12	32	60	38	83
409.H14	40 - 14	40	14	34	80	38	83
409.H16	40 - 16	40	16	38	90	73	83
409.H18	40 - 18	40	18	40	60	73	83
409.H20	40 - 20	40	20	42	95	73	83
409.H25	40 - 25	40	25	50	95	73	83
409.H32	40 - 32	40	32	60	95	73	83
509.H06	50 - 06	50	6	26	55	33	98
509.H08	50 - 08	50	8	28	55	33	98
509.H10	50 - 10	50	10	30	55	33	98
509.H12	50 - 12	50	12	32	60	38	98
509.H14	50 - 14	50	14	34	60	38	98
509.H16	50 - 16	50	16	38	95	65	98
509.H18	50 - 18	50	18	40	95	65	98
509.H20	50 - 20	50	20	42	95	65	98
509.H25	50 - 25	50	25	50	95	65	98
509.H32	50 - 32	50	32	60	95	65	98

Lieferumfang: Mit Spannschlüssel  
Delivery: With wrench  
Livraison: Avec clé de serrage



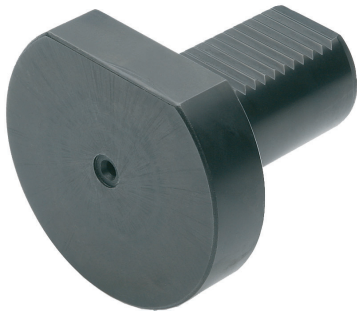

**Verwendung:**  
Zum Verschließen der Aufnahmebohrung  
am Werkzeugrevolver.

**Application:**  
For sealing the spindle of the turret.

**Application:**  
Pour boucher la broche du tour.

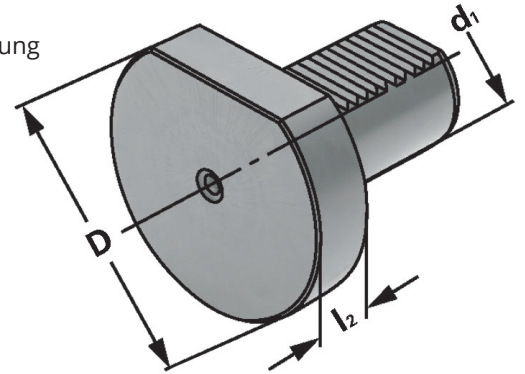

ISO 10889  
DIN 69880

Z2

Bestell-Nr. Order no. Référence	Abmessung Size Dimension	d <sub>1</sub>	D	l <sub>2</sub>
169.29.13	Z2 - 16 × 13	16	40	13
209.29.16	Z2 - 20 × 16	20	50	16
259.29.16	Z2 - 25 × 16	25	58	16
309.29.20	Z2 - 30 × 16	30	68	16
409.29.20	Z2 - 40 × 20	40	83	20
509.29.20	Z2 - 50 × 20	50	98	20



**Verwendung:**  
Zum Verschließen der Aufnahmebohrung  
am Werkzeugrevolver.

**Application:**  
*For sealing the spindle of the turret.*

**Application:**  
Pour boucher la broche du tour.

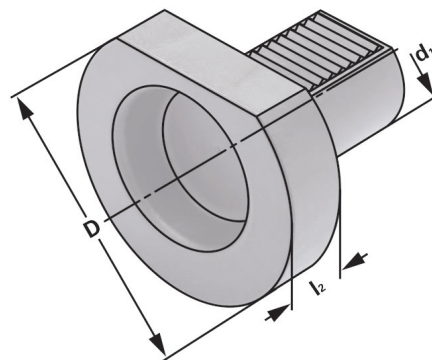

ISO 10889  
DIN 69880

Z2

Bestell-Nr. Order no. Référence	Abmessung Size Dimension	$d_1$	D	$l_2$
169.30.13	Z2 - 16 × 13	16	40	13
209.30.16	Z2 - 20 × 16	20	50	16
259.30.16	Z2 - 25 × 16	25	58	16
309.30.16	Z2 - 30 × 16	30	68	16
409.30.20	Z2 - 40 × 20	40	83	20
509.30.20	Z2 - 50 × 20	50	98	20





**Verwendung:**  
Zur Aufnahme von Werkzeugen mit Zylinderschaft.  
**Application:**  
For mounting tools with straight shank.  
**Application:**  
Pour le serrage d'outils avec queue cylindrique.

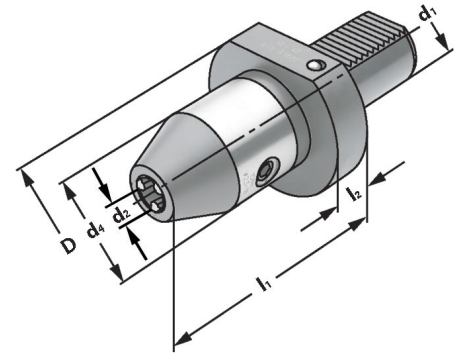

ISO 10889  
DIN 69880

$\nearrow \leq 0,030$

14.04

Bestell-Nr. Order no. Référence	d <sub>1</sub>	Spannbereich Capacity Capacité	d <sub>2</sub>	d <sub>4</sub>	D	l <sub>1</sub>	l <sub>2</sub>
209.15.13	20	1,0 - 13		50	50	88	17
309.15.13	30	1,0 - 13		50	68	93	22
309.15.16	30	2,5 - 16		50	68	98	22
409.15.13	40	1,0 - 13		50	83	93	22
409.15.16	40	2,5 - 16		50	83	98	22
509.15.13	50	1,0 - 13		50	98	101	30
509.15.16	50	2,5 - 16		50	98	106	30

7

**Hinweis:** Hohe Präzision und Rundlaufgenauigkeit von  $\leq 0,03$  mm. Sichere Spannung des Werkzeuges durch mechanische Spannkraftverstärkung. Kein selbständiges Lösen der Spannung während der Bearbeitung bei Links- oder Rechtslauf. Spannen und Lösen mit Sechskantschlüssel.

**Note:** High precision and accurate concentricity of  $\leq 0.03$  mm. Secure gripping of the tool through mechanical amplification of the clamping force. No automatic slackening of the clamping force while machining with either clockwise or counter clockwise rotation. Clamping and releasing effected by means of an Allen wrench.

**Observation:** Précision élevée et exactitude de circularité de  $\leq 0,03$  mm. Serrage sûr de l'outil grâce à l'amplification de la force de serrage. Pas de desserrage intempestif en cours d'usinage lors de la rotation la gauche ou la droite. Serrage et desserrage en utilisant un clé sur à fourche.

**Lieferumfang:** Mit Spannschlüssel  
**Delivery:** With wrench  
**Livraison:** Avec clé de serrage



10.23



CNC-Drill chucks with coolant supply via spray nozzles  
Mandrins de perçage CNC avec arrosage par gicleurs

DIN 69880 (VDI 3425)



**Verwendung:**  
Zur Aufnahme von Werkzeugen mit Zylinderschaft.  
**Application:**  
For mounting tools with straight shanks.  
**Application:**  
Pour le serrage d'outils à queue cylindrique.

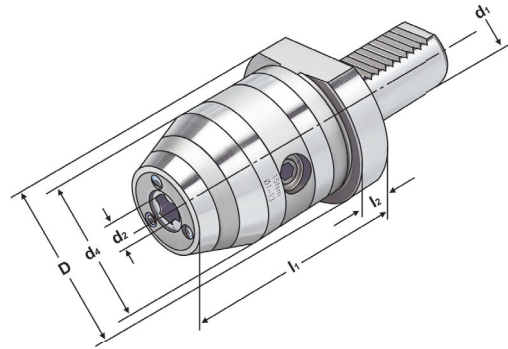

ISO 10889  
DIN 69880

$\nearrow \leq 0,030$

14.04

Bestell-Nr. Order no. Référence	d <sub>1</sub>	Spannbereich Capacity Capacité	d <sub>4</sub>	D	l <sub>1</sub>	l <sub>2</sub>
169.15.10.K	16	0,3 - 10	40	40	46	10
209.15.10.K	20	0,3 - 10	50	50	41	10
259.15.13.K	25	1,0 - 13	50	55	87	12
309.15.13.K	30	1,0 - 13	50	68	87	22
309.15.16.K	30	2,5 - 16	55	68	92	22
409.15.13.K	40	1,0 - 13	50	83	88	22
409.15.16.K	40	2,5 - 16	55	83	93	22
509.15.16.K	50	2,5 - 16	55	98	102	



**Hinweis:** Hohe Präzision und Rundlaufgenauigkeit von  $\leq 0,03$  mm. Sichere Spannung des Werkzeuges durch mechanische Spannkraftverstärkung. Kein selbständiges Lösen der Spannung während der Bearbeitung bei Links- oder Rechtslauf. Spannen und Lösen mit Sechskantschlüssel.

**Note:** High precision and accurate concentricity of  $\leq 0.03$  mm. Secure gripping of the tool through mechanical amplification of the clamping force. No automatic slacking of the clamping force while machining with either clockwise or counter clockwise rotation. Clamping and releasing effected by means of an Allen wrench.

**Observation:** Précision élevée et exactitude de circularité de  $\leq 0,03$  mm. Serrage sûr de l'outil grâce à l'amplification de la force de serrage. Pas de desserrage intempestif en cours d'usinage lors de la rotation la gauche ou la droite. Serrage et desserrage en utilisant un clé sur à fourche.

**Lieferumfang:** Mit Spannschlüssel  
**Delivery:** With wrench  
**Livraison:** Avec clé de serrage



10.23



Quick change tapping chucks with length compensation on compression and expansion

Mandrins de taraudage à changement rapide avec compensation longitudinale à la compression et traction



**Verwendung:**

Zur Aufnahme von Schnellwechsel-Einsätzen für Gewindebohrer.

**Application:**

For the chucking of Quick change taps for threading taps.

**Application:**

Pour le serrage des inserts de changement rapide pour tarauds.

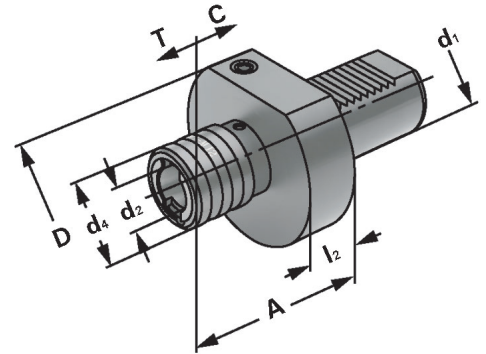

ISO 10889  
DIN 69880

14.04

Bestell-Nr. Order no. Référence	d <sub>1</sub>	Spannbereich Capacity Capacité	Größe Size Taille	D	A	d <sub>4</sub>	d <sub>2</sub>	C	T
209.16.12	20	M3 - M14	1	50	67	38	19	7	7
259.16.12	25	M3 - M14	1	58	55	38	19	7	7
309.16.12	30	M3 - M14	1	58	58	36	19	7	7
309.16.20	30	M5 - M22	2	81	81	53	31	12	12
409.16.12	40	M3 - M14	1	58	58	36	19	7	7
409.16.20	40	M5 - M22	2	81	81	53	31	12	12
509.16.12	50	M3 - M14	1	58	56	36	19	7	7
509.16.20	50	M5 - M22	2	81	80	53	31	12	12





ohne Längenausgleich auf Druck und Zug

DIN 69880 (VDI 3425)

Quick change tapping chucks without length compensation on compression and expansion  
 Mandrins de taraudage à changement rapide sans compensation longitudinale à la compression et traction



**Verwendung:**  
 Für Bearbeitungszentren mit Synchronspindel. Zur Aufnahme von Schnellwechsel-Einsätzen für Gewindebohrer.

**Application:**  
 On machining centres with synchronised spindles. For the chucking of Quick change taps for threading taps.

**Application:**  
 Sur centres d'usinage avec axe synchrone. Pour le serrage des inserts de changement rapide pour tarauds.

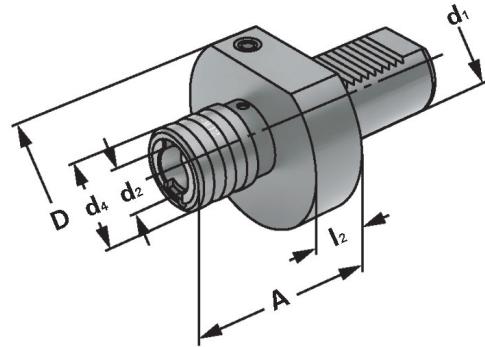

ISO 10889  
 DIN 69880



Bestell-Nr. Order no. Référence	d <sub>1</sub>	Spannbereich Capacity Capacité	Größe Size Taille	D	A	d <sub>4</sub>	d <sub>2</sub>
309.16.12.1	30	M3 - M14	1	68	55	36	19
309.16.20.1	30	M5 - M22	2	68	77	53	31
409.16.12.1	40	M3 - M14	1	83	55	36	19
409.16.20.1	40	M5 - M22	2	83	77	53	31





**Verwendung:**  
Zur Herstellung von Sonderwerkzeugen.  
**Application:**  
*For the manufacturing of special tools.*  
**Application:**  
Pour la fabrication d'outils spéciaux.

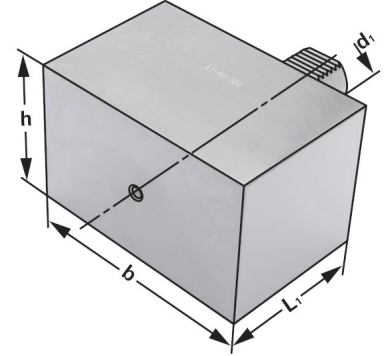

ISO 10889  
DIN 69880

A1

Bestell-Nr. Order no. Référence	Abmessung Size Dimension	d <sub>1</sub>	L <sub>1</sub>	h	b
169.17.12	A1 - 16 - 78 - 44 - 44	16	44	44	78
209.17.16	A1 - 20 - 100 - 60 - 65	20	65	60	100
259.17.16	A1 - 25 - 100 - 60 - 75	25	75	60	100
309.17.20	A1 - 30 - 130 - 76 - 85	30	85	76	130
409.17.25	A1 - 40 - 151 - 96 - 100	40	100	96	151
509.17.32	A1 - 50 - 160 - 120 - 125	50	125	120	160





Soft blank fomr A2, round  
Porte-outils ebauche forme A2, ronde



**Verwendung:**  
Zur Herstellung von Sonderwerkzeugen.  
**Application:**  
*For the manufacturing of special tools.*  
**Application:**  
Pour la fabrication d'outils spéciaux.

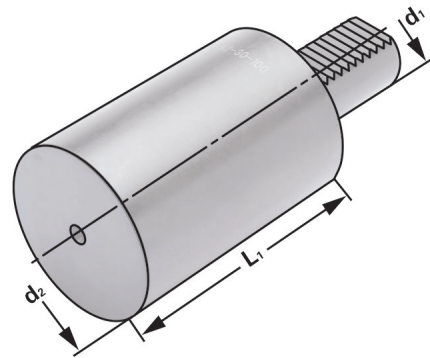

ISO 10889  
DIN 69880

A2

Bestell-Nr. Order no. Référence	Abmessung Size Dimension	d <sub>1</sub>	d <sub>2</sub>	L <sub>1</sub>
169.19.12	A2 - 16 - 40 - 60	16	40	60
209.19.16	A2 - 20 - 50 - 70	20	50	70
259.19.16	A2 - 25 - 50 - 80	25	58	80
259.19.17	A2 - 25 - 50 - 200	25	58	200
309.19.20	A2 - 30 - 68 - 100	30	68	100
309.19.21	A2 - 30 - 68 - 240	30	68	240
409.19.20	A2 - 40 - 83 - 120	40	83	120
409.19.21	A2 - 40 - 83 - 320	40	83	320
509.19.32	A2 - 50 - 98 - 135	50	98	135
509.19.33	A2 - 50 - 98 - 400	50	98	400



**Verwendung:**  
Zur Abnahme von Werkzeugmaschinen gemäß ISO-Empfehlung R230 oder zur Überprüfung der Werkzeugspindel.

**Application:**  
For the inspection of machine tools according to ISO recommendation R230 or for testing the tool spindle.

**Application:**  
Pour l'inspection de machine-outils suite à la recommandation ISO R230 ou pour la vérification de la broche.

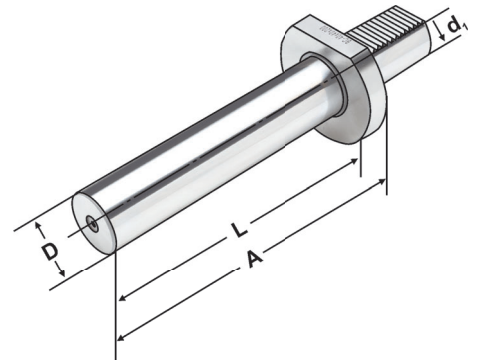

ISO 10889  
DIN 69880

$\nabla \leq 0,003$

Bestell-Nr. Order no. Référence	Abmessung Size Dimension	d <sub>1</sub>	D	A	L
169.18.30	16 - 30 - 120	16	30	120	105
209.18.40	20 - 40 - 150	20	40	150	130
259.18.40	25 - 40 - 150	25	40	150	135
309.18.40	30 - 40 - 200	30	40	230	185
409.18.40	40 - 40 - 200	40	40	200	185
509.18.40	50 - 40 - 200	50	40	200	185

7

## Holzkasten für Kontrolldorne

Wooden box for test arbors

Coffret en bois pour mandrins de contrôle



**Verwendung:**  
Zur Aufbewahrung von Kontrolldornen.

**Application:**  
For the storage of test arbors.

**Application:**  
Pour la conservation de mandrins de contrôle.



Bestell-Nr.  
Order no.  
Référence

Abmessung  
Size  
Dimension

für Kegelgrößen  
for cones  
pour cônes

701.18

460 × 130 × 115

VDI 16 / 20 / 25 / 30 / 40 / 50

*Shims*  
Sous-plaquettes



**Verwendung:**  
Unterlegplatten für VDI Werkzeughalter  
**Application:**  
*Shims for VDI toolholder*  
**Application:**  
Assiettes pour porte-outils VDI

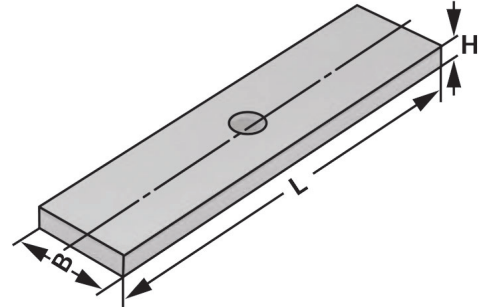

Bestell-Nr. Order no. Référence	B	H	L
209.16.01	14	4	54
259.16.01	13,5	4	49
309.20.01	16	4	69
409.25.01	20	5	84
509.32.01	23	7	99



O-Ringe

*O-ring*  
Joints torique



**Verwendung:**  
O-Ringe zum abdichten des VDI Schaftes  
**Application:**  
*O-Rings for sealing VDI shanks*  
**Application:**  
Joints toriques pour étancher des queues VDI

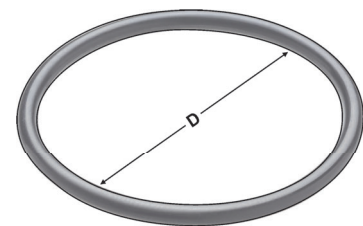

Bestell-Nr. Order no. Référence	D
Z.169.RING	16
Z.209.RING	20
Z.259.RING	25
Z.309.RING	30
Z.409.RING	40
Z.509.RING	50





**Verwendung:**  
Spritzdüsen für Kühlmittelzufuhr für VDI  
Werkzeughalter

**Application:**  
*Sprayer nozzles for cooling by VDI toolholders*

**Application:**  
Gicleurs pour l'alimentation en refroidisse-  
ment pour porte-outils VDI

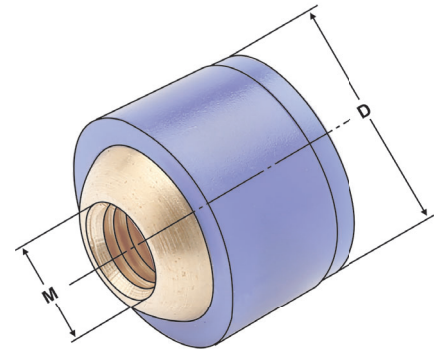

Bestell-Nr. Order no. Référence	D	M
703.08	8	3
703.10	10	4
703.12	12	5
703.14	14	6





*Ball sprayer nozzles (brass)*  
Gicleurs (laiton)



**Verwendung:**  
Spritzdüsen für Kühlmittelzufuhr für VDI Werkzeughalter

**Application:**  
*Sprayer nozzles for cooling by VDI toolholders*

**Application:**  
Gicleurs pour l'alimentation en refroidissement pour porte-outils VDI

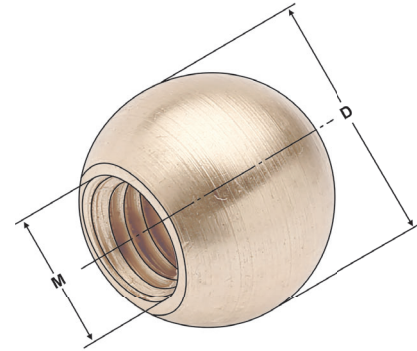

Bestell-Nr. Order no. Référence	D	M	VDI
703.08.ME	8	5	16
703.10.ME	10	6	16 + 25 + 30 + 40
703.12.ME	12	6	50
703.14 .ME	14	8	



## Kühlmittelrohr (Messing)

*Coolant tube (brass)*  
Canule de lubrification (laiton)



**Verwendung:**  
Kühlmittelrohr für Kühlmittelzufuhr für VDI Werkzeughalter

**Application:**  
*Coolant tube for cooling by VDI toolholders*

**Application:**  
Canule de lubrification pour l'alimentation en refroidissement pour porte-outils VDI

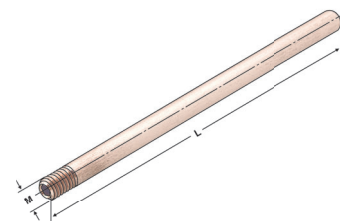

Bestell-Nr. Order no. Référence	L	M	Ø
Z.VDI.700.200	100	5	Ø 3mm
Z.VDI.700.100	100	6	Ø 3mm



Static and power-driven tools for HAAS BMT 65  
Porte-outils statiques ou rotatifs pour HAAS BMT 65

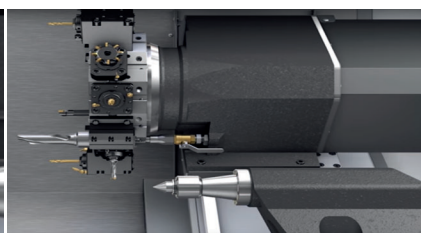
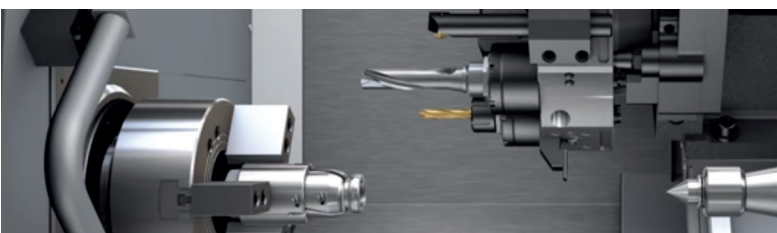
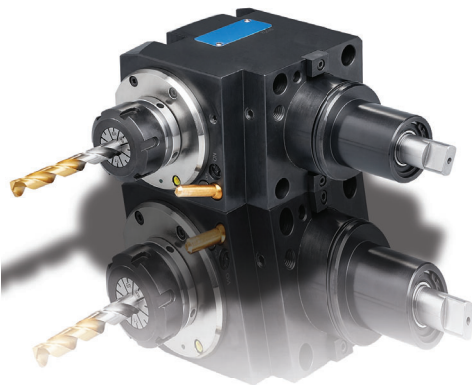
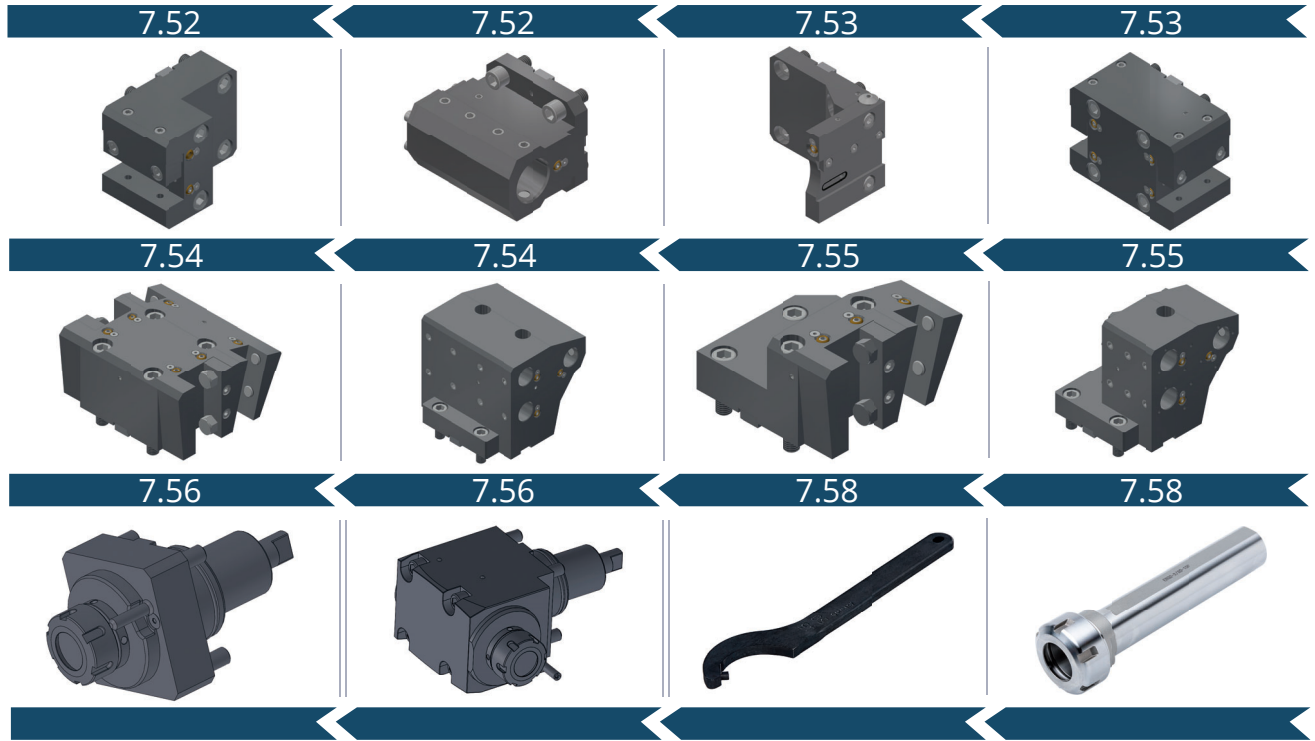



Toolholder with square-longitudinal receptacle doubled  
 Manche à outils avec porte-outils longitudinal carré double

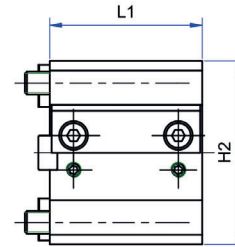
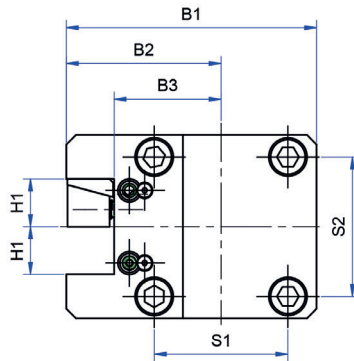
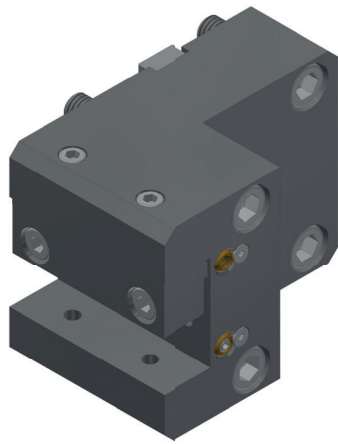

HAAS ST-Line BMT 65 EC

Bestell-Nr. Order no. Référence	H1	H2	B1	B2	B3	L1	S1	S2
AW.102.065.25.755	25	96	131	81	56	80	70	73



Zylinderschaftaufnahme

Cylindrical shank receptacle  
 Support de tige cylindrique

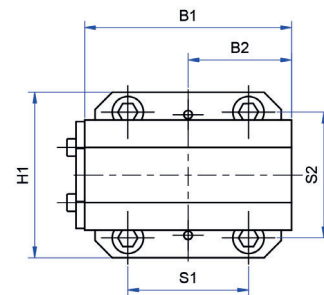
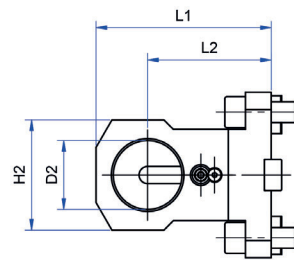
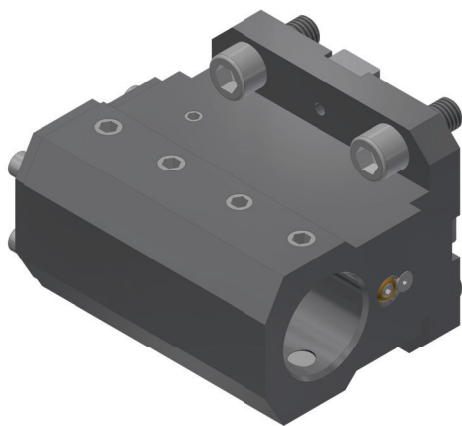

HAAS ST-Line BMT 65 IC | EC

Bestell-Nr. Order no. Référence	D2	H1	H2	B1	B2	L1	L2	S1	S2
AW.107.265.40.750	40	96	64	120	60	102	72	70	73





Front cut-off toolholder

Porte-outils de tronçonnage frontal

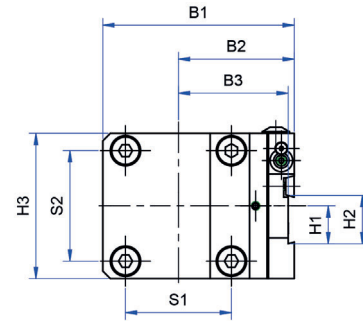
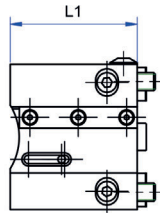
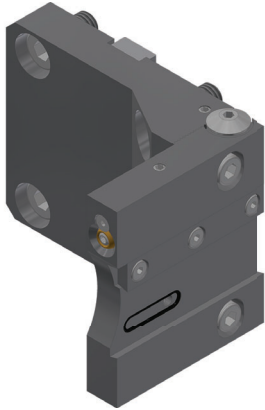

HAAS ST-Line

BMT 65



IC | EC

Bestell-Nr.  
Order no.  
Référence

AW.105.065.26.753

H1

25

H2

32

H3

96

B1

126,5

B2

76,5

B3

72,5

L1

84

S1

70

S2

73

7

Werkzeughalter mit Vierkant-Mehrfachaufnahme

Toolholder with square-multi-receptacle

Manche à outils avec porte-outils multiple carré

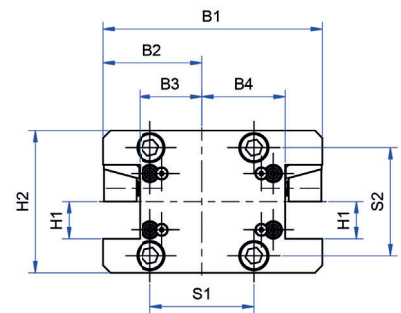
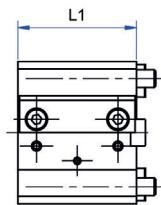
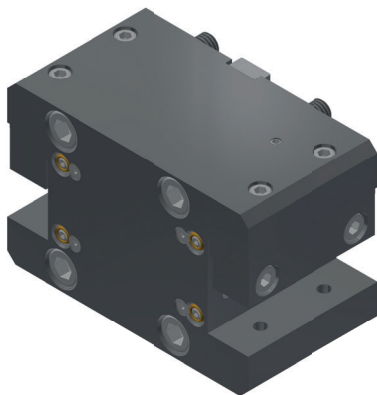

HAAS ST-Line

BMT 65



EC

Bestell-Nr.  
Order no.  
Référence

AW.103.065.25.755

H1

25

H2

96

B1

149

B2

68

B3

43

B4

56

L1

80

S1

70

S2

73



Toolholder with square-multi-receptacle  
Manche à outils avec porte-outils multiple carré

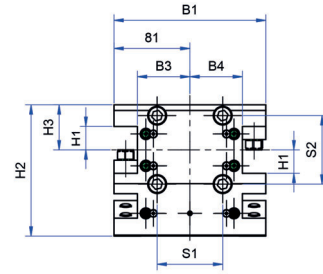
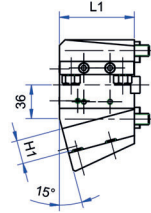
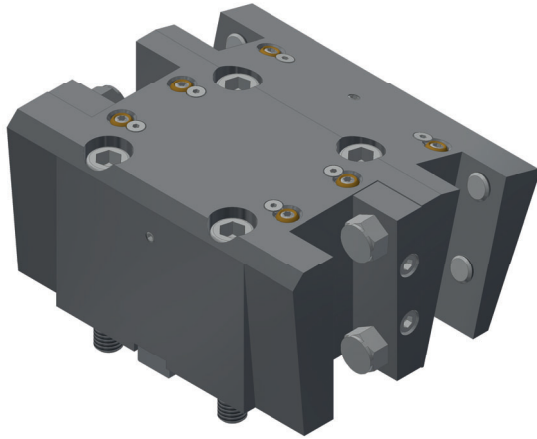

HAAS ST-Line BMT 65 EC

Bestell-Nr. Order no. Référence	H1	H2	H3	B1	B2	B3	B4	L1	S1	S2
AW.103.065.25.756	25	139,873	48	162	81	56	56	80	70	73

### Zylinderschaftaufnahme

Cylindrical shank receptacle  
Support de tige cylindrique

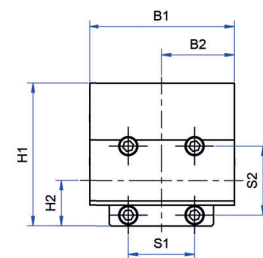
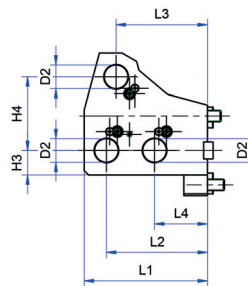
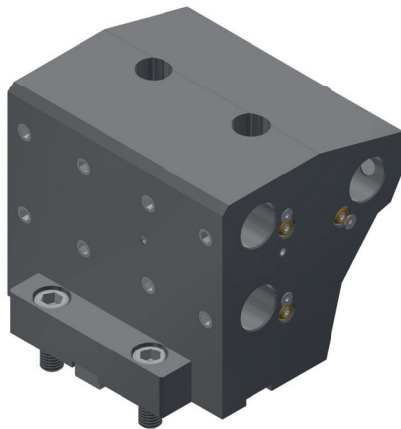

HAAS ST-Line BMT 65 IC | EC

Bestell-Nr. Order no. Référence	D2	H1	H2	H3	H4	B1	B2	L1	L2	L3	L4	S1	S2
AW.107.265.25.756	25	151	48	26	77,82	154	77	130,5	107	96,755	56	70	73

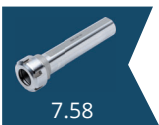



Toolholder with square-multi-receptacle  
Manche à outils avec porte-outils multiple carré

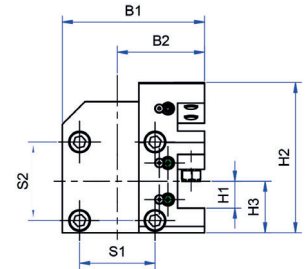
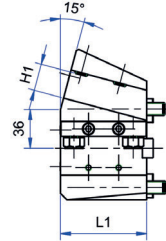
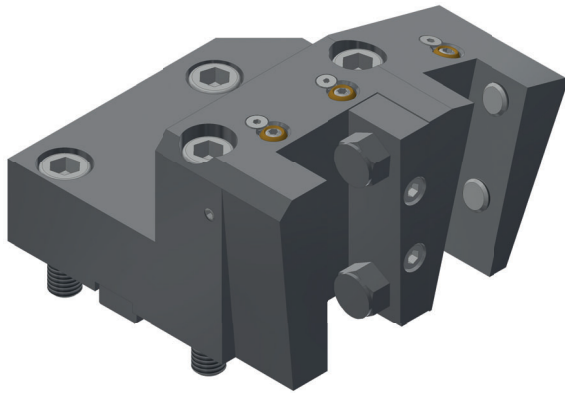

HAAS ST-Line

BMT 65



EC

Bestell-Nr.  
Order no.  
Référence

	H1	H2	H3	B1	B2	L1	S1	S2
AW.103.065.25.753	25	139,873	48	132	81	80	70	73

7

### Zylinderschaftaufnahme

Cylindrical shank receptacle  
Support de tige cylindrique

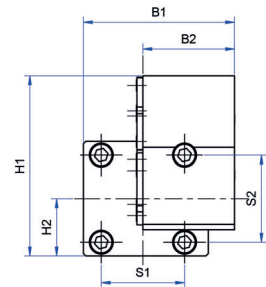
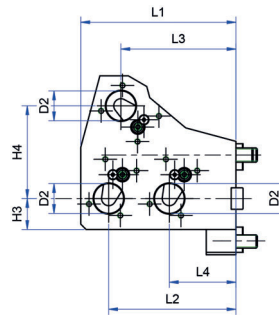
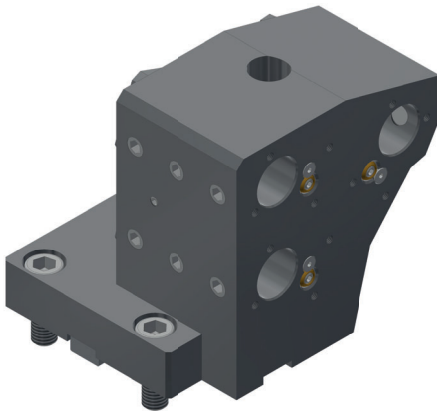

HAAS ST-Line

BMT 65



IC | EC

Bestell-Nr.  
Order no.  
Référence

	D2	H1	H2	H3	H4	B1	B2	L1	L2	L3	L4	S1	S2
AW.107.265.25.753	25	151	48	26	77,82	127	77	130,5	107	96,755	56	70	73



Axial drilling and milling head for external cooling

Tête d'alésage et de fraisage axiale pour refroidissement externe

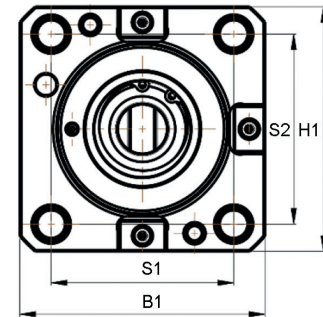
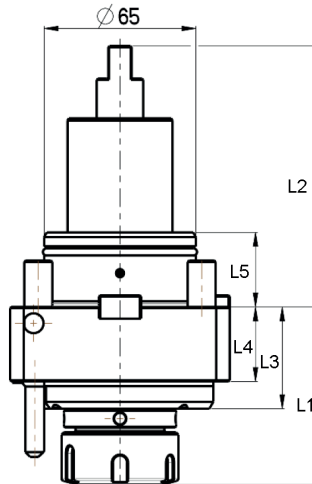
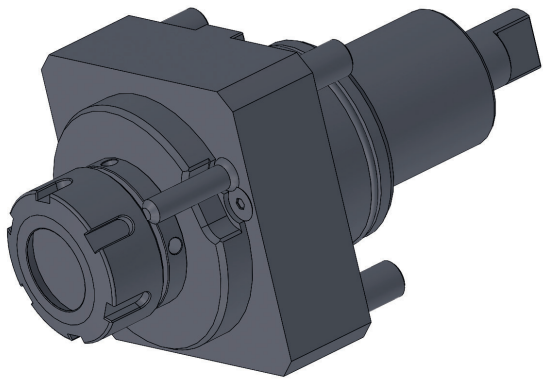

HAAS ST-Line | BMT 65 | EC | ER 32 | 1:1

Bestell-Nr. Order no. Référence	B1	H1	S1	S2	L1	L2	L3	L4	L5	n max. min-1	T max. Nm
AW.221.065.20.751	94	94	70	73	76,3	112	43,7	32	32	6000	70

Radial Bohr- und Fräskopf für externe Kühlung

Radial drilling and milling head for external cooling

Tête d'alésage et de fraisage radiale pour refroidissement externe

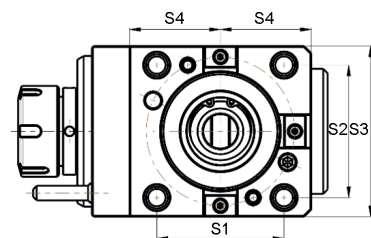
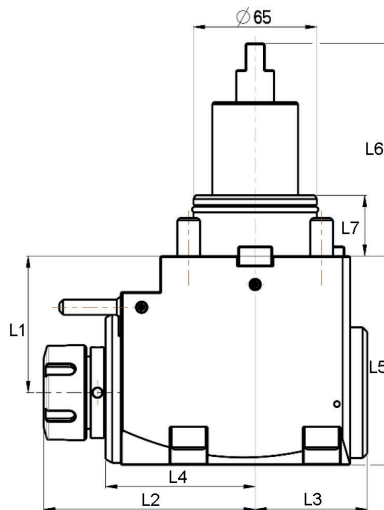
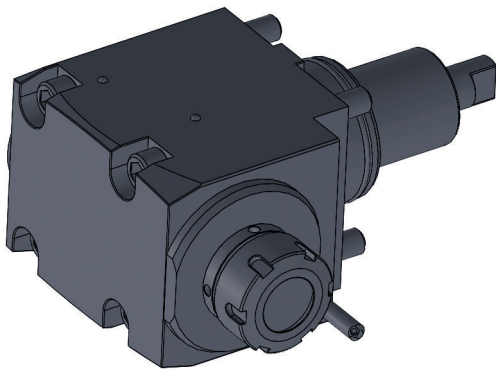

HAAS ST-Line | BMT 65 | EC | ER 32 | 1:1

Bestell-Nr. Order no. Référence	S1	S2	S3	S4	L1	L2	L3	L4	L5	L6	L7	n max. min-1	T max. Nm
AW.221.265.20.751	70	73	94	50	72	111,3	59	78,7	110	112	32	6000	70







Axial drilling and milling head for internal and external cooling

Tête d'alésage et de fraisage axiale pour refroidissement interne et externe

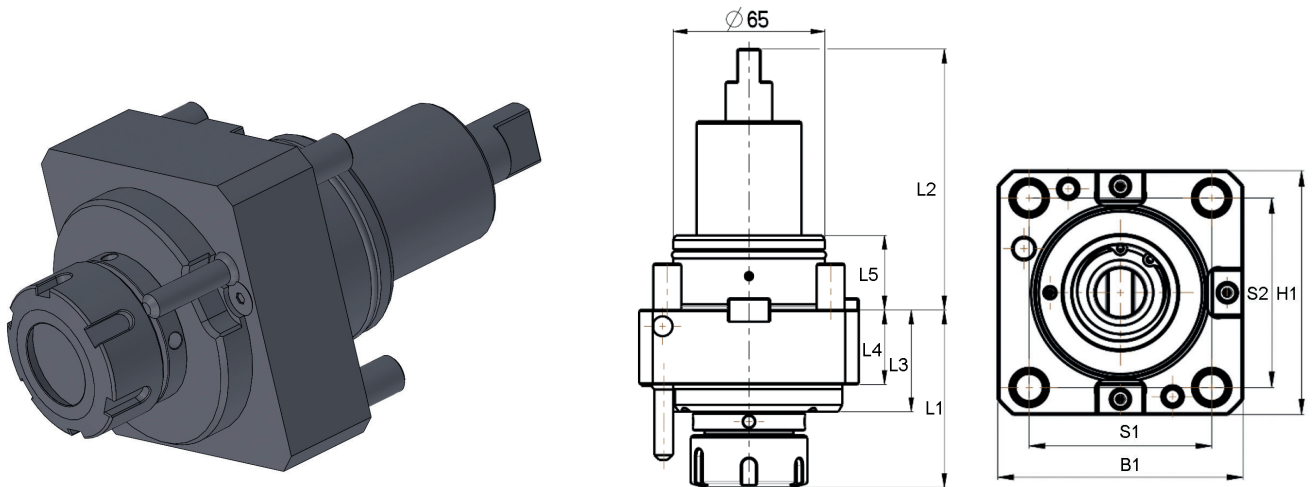

HAAS ST-Line | BMT 65 | IC | EC | ER 32 | 1:1

Bestell-Nr. Order no. Référence	B1	H1	S1	S2	L1	L2	L3	L4	L5	n max. min-1	T max. Nm
AW.221.065.20.756	94	94	70	73	76,3	112	43,7	32	32	6000	70



Radial Bohr- und Fräskopf für interne und externe Kühlung

Axial drilling and milling head for internal and external cooling

Tête d'alésage et de fraisage axiale pour refroidissement interne et externe

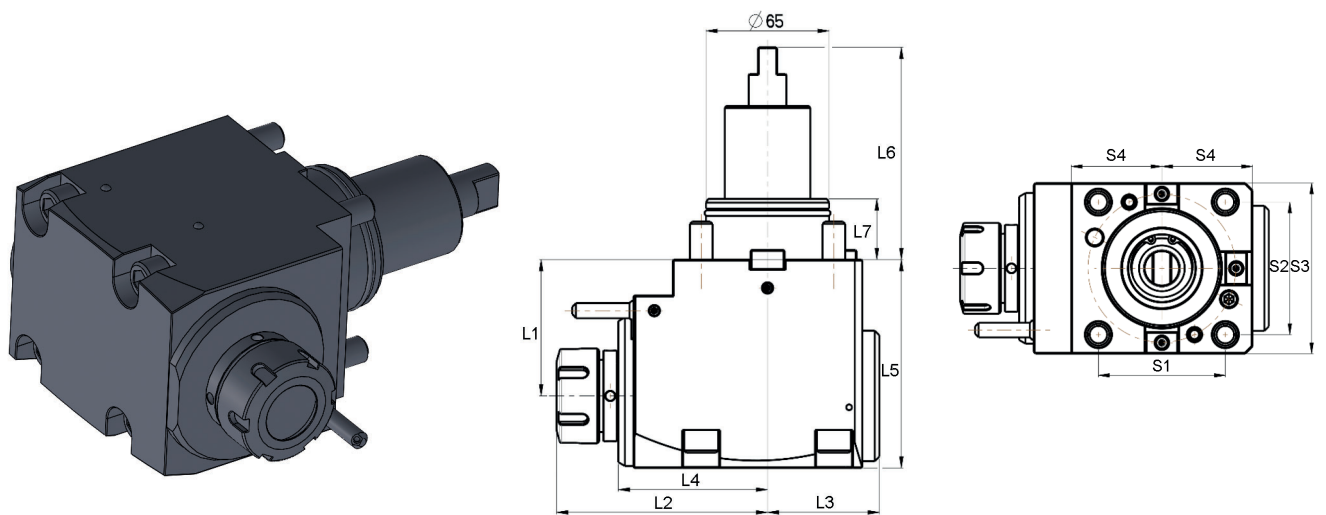

HAAS ST-Line | BMT 65 | IC | EC | ER 32 | 1:1

Bestell-Nr. Order no. Référence	S1	S2	S3	S4	L1	L2	L3	L4	L5	L6	L7	n max. min-1	T max. Nm
AW.221.265.20.756	70	73	94	50	72	111,3	59	78,7	110	112	32	6000	70



## DIN 6499 (ISO 15488) System ER

Collet chucks with straight shank with with clamping surface for collets DIN 6499 (ISO 15488) ER-system  
Mandrins à pinces à queue cylindrique avec surface de serrage pour pinces DIN 6499 (ISO 15488) ER



**Verwendung:**  
Zur Aufnahme von Werkzeugen mit Zylinderschaft in Spannzangen.  
**Application:**  
For mounting straight-shank tools in collets.  
**Application:**  
Pour le serrage d'outils avec queue cylindrique dans des pinces de serrage.

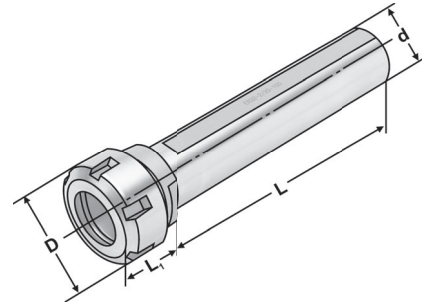

Bestell-Nr. Order no. Référence	d <sub>H6</sub>	Spannbereich Capacity Capacité	L	L <sub>1</sub>	D
120.02.04.20.1	40	2 - 20 (ER 32)	120	41	50

## Hakenschlüssel mit Zapfen

Hook wrench with pin 45-50 | ER32 | 2-20 |  
Clé à ergot rond 45-50 | ER32 | 2-20 |



Bestell-Nr. Order no. Référence	Spannbereich Capacity Capacité
AW.SE4550	45 - 50 (ER 32)

## Spannschlüssel für Spannmuttern System ER

Wrenches for clamping nuts ER-system  
Clés de serrage pour écrous de serrage système ER



Bestell-Nr. Order no. Référence	Spannbereich Capacity Capacité
02.20	2 - 20 (ER 32)



# Anfrageformular für angetriebene Werkzeuge

Request Form for Driven Tools  
Formulaire de demande pour outils entraînés

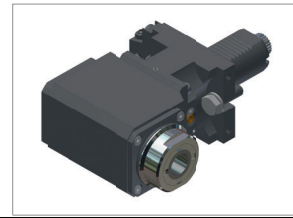
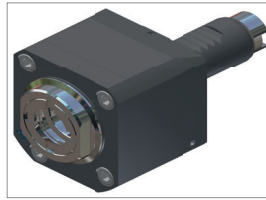
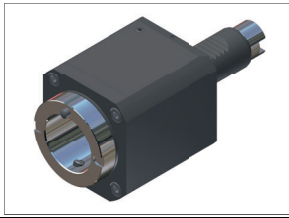

## Maschinen-Grunddaten:

Machine basic data / Données de base machine

Maschinen Hersteller / Typ: \_\_\_\_\_

Machinery manufacturer / Fabricant-type de la machine

Drehzahl Revolverspindel (n): \_\_\_\_\_

Number of revolutions turret spindle / Nombres révolutions broche de tourelle

Revolverhersteller / Typ: \_\_\_\_\_

Turret manufacturer / Fabricant-type de tourelle

Drehmoment Revolverspindel (T): \_\_\_\_\_

Torque turret spindle / Torque broche de tourelle

## Revolvertyp:

Turret typ / Type de tourelle

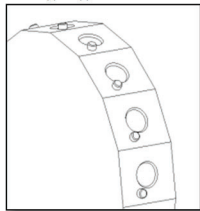

Sternrevolver  
Star turret / Tourelle étoile

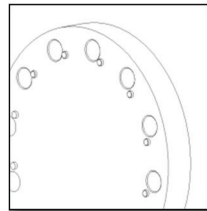

Scheibenrevolver  
Disk turret / Tourelle disque

## Revolveraufnahme:

Turret dimensions / Dimension tourelle

VDI:  z.B 25;30;40...  
e.g. / p. ex. 25;30;40...

BMT:  z.B 45;55;65...  
e.g. / p. ex. 45;55;65...

CDI:  z.B 68;80...  
e.g. / p. ex. 68;80...

Sonstiges: \_\_\_\_\_  
Other / Autre

## Antriebstyp:

Drive type / Type d'entraînement

z.B: DIN1809; DIN5480; DIN 5482  
e.g.: DIN 1809; DIN 5480; DIN 5482  
p. ex. DIN 1809; DIN 5480; DIN 5482

Zeichnung im Anhang:   
Drawing in the appendix / Dessin en annexe

## Werkzeugtyp:

Tool type / Type d'outil

Axial: Axial/Axial

Desaxial: Desaxial / Desaxial

Radial: Radial / Radial

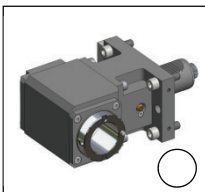
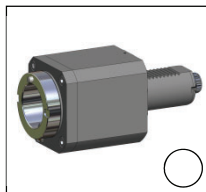

Radial: zurückgesetzt  
Radially reset / Radial réinitialisé

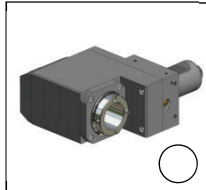

Schwenkopf:  
Swivel head / Tête pivotante

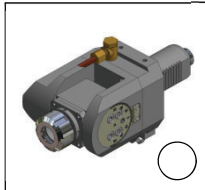

Radial: zweifach  
Radial double / Radial doublement

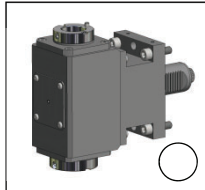

## Spindelrichtung:

Spindle direction / Direction de broche

Rechtes Werkzeug:  
Right tool / Outil de droite

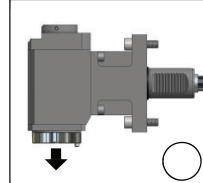

Linkes Werkzeug:  
Left tool / Outil de gauche

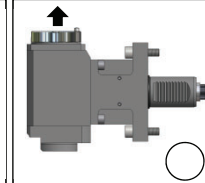

Doppelverzahnung:  
Double toothing / Double denture

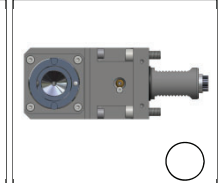

## Werkzeugaufnahme:

Tool holder / Porte-outil

Spannzange:  
Collet / Pince serrage

HW:

HW / HW

Capto:

Capto / Capto

Fräsdorn:

Abor / Arbore de

Größe  
Size / Taille

HSK:

HSK / HSK

Hydrodehn:

Hydrodehn / Expans. Hydr.

Weldon:

Weldon / Weldon

Sonstiges: \_\_\_\_\_

Other / Autre

Größe  
Size / Taille

## Übersetzungsverhältnis:

Transmission ratio / Rapport de transmission

n1 : n2 =  :

## Kühlmittelzufuhr:

Coolant supply / Alimentation de réfrigérant

Nein   
No / Non

Extern   
External / Externe

Intern   
Internal / Interne

Druck  Bar  
Pressure / Pression

## Angaben zur Bearbeitung:

Notes for the application / Informations pour le traitement

Bohren:

Drill / Percage

Werkzeug-Ø:   
Tool Ø / Ø outil

Fräsen:

Mill / Fraisage

Werkzeug-Ø:   
Tool Ø / Ø outil

schlichten  
finishing / finition

schruppen  
roughing / ébauche

Gewindeschneiden:

Threading / Taraudage

Werkzeug-Ø:   
Tool Ø / Ø outil

## Maße Axial u. Desaxiale Werkzeuge

Dimensions axial and desaxial tools / Dimensions outils axiaux et desaxiaux

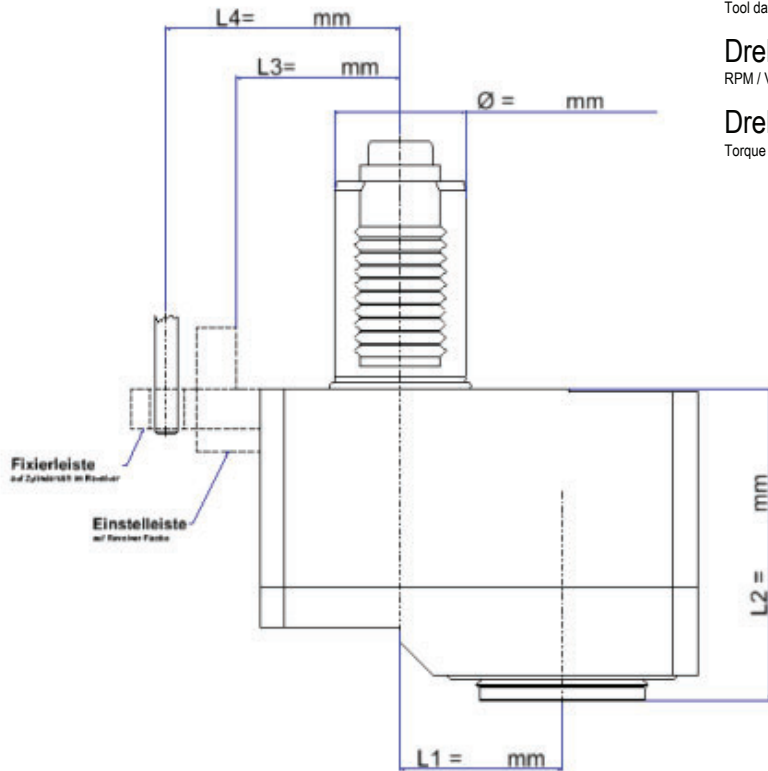

### Werkzeug Daten:

Tool data / Données de l'outil

Drehzahl n max.: \_\_\_\_\_ 1/min

RPM / Vitesse de rot

Drehmoment T max.: \_\_\_\_\_ Nm

Torque / Torque

### Notizen:

Notes / Notes

---

---

---

---

---

---

---

---

---

---

## Maße Radiale Werkzeuge

Dimensions radial tools / Dimensions outils radiaux

### Werkzeug Daten:

Tool data / Données l'outil

Drehzahl n max.: \_\_\_\_\_ 1/min

RPM / Vitesse de rot

Drehmoment T max.: \_\_\_\_\_ Nm

Torque / Torque

### Notizen:

Notes / Notes

---

---

---

---

---

---

---

---

---

---

